

非鉄金属加工用コーティングシリーズ Coating series for non-ferrous metals

SD(S-DLC)コーティングシリーズ

SD(S-DLC) Coating series

SD(S-DLC)



株式会社 **MOLDINO**
MOLDINO Tool Engineering, Ltd.

New Product News No.0805-13 2022-10

硬度70GPaを超える驚異の新コーティング

A phenomenal new coating with hardness exceeding 70GPa

機能と特長

Features & Characteristics

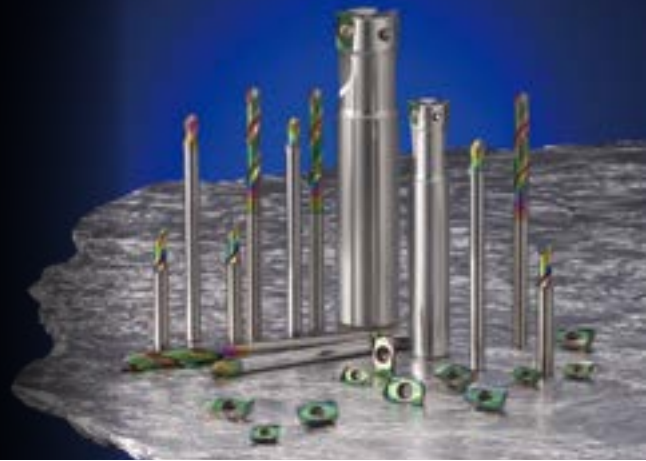

高硬度 High hardness

ダイヤモンドに限りなく近いDLCコーティングです。

硬度：70GPa以上

The DLC coating infinitely close to that of diamond.
Hardness: More than 70GPa

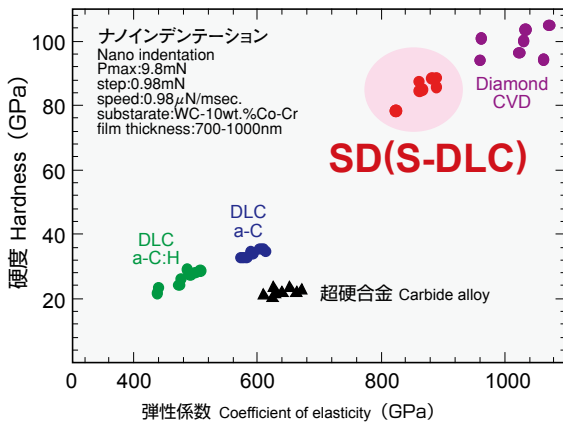

高耐熱温度 High heat-resistance temperature

不純物が少なく高耐熱性、高能率加工が可能です。

耐熱温度：600℃ 大気中600℃でも高硬度を維持！

Impurities are low, providing high heat resistance and enabling high-efficiency machining.
Withstand temperature: 600°C Maintains high hardness even in an atmosphere of 600°C!

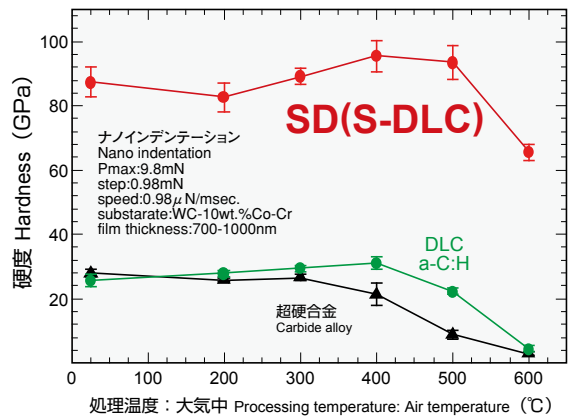

高能率切削加工 High-efficiency cutting machining

アルミ合金や樹脂の切削加工に効果を発揮、発熱が少なくドライ切削に最適です。

Cutting machining of aluminum alloys or resins showcases the effects, with low heat generation making it ideal for dry cutting.

φ6×2枚刃 Flutes エポックSD(S-DLC)スクエア Epoch SD(S-DLC) Square (EPAS2060-SD)
A5052溝切削加工 Slotting 回転数 Revolution: 12,000min⁻¹ 溝深さ Groove depth: 3mm
ドライ切削 Dry cutting

従来DLC(a-C)
Conventional DLC

従来DLC(a-C:H)
Conventional DLC

超硬合金
Carbide alloy

SD(S-DLC) 溶着なし&継続可 No welding, interrupted cutting is possible.

バリ大
Large amount of burrs

溶着&バリ大
Welding and large amount of burrs

溶着&バリ大
Welding and large amount of burrs

送り速度 Feed rate (mm/min)

超平滑 Ultra smooth

新フィルタリング技術を採用し、コーティングに含まれるドロップレットを除去。極めて平滑なDLCコーティングです。

A new filtering technology is utilized to remove droplet from the coating to provide the extremely smooth DLC coating.

■超硬インサートの表面ドロップレットの比較
Comparison of surface droplet on carbide insert

超平滑(新フィルタリング技術)
Ultra smooth (New filtering technology)

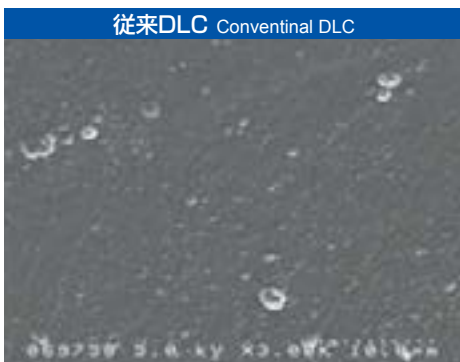

注意:SD(S-DLC)コーティングは密度が高く光学的に透明です。干渉色を示しますが性能には影響ありません。
Note: SD(S-DLC) coating has high density and is optically clear. Some interference color may be exhibited but this does not affect performance.

高耐凝着 High adhesion resistance

鋭い刃先エッジ、刃先の溶着防止。摩擦係数:0.1以下 Sharp cutting edge prevents welding. Friction coefficient: 0.1 or less

■ ボールオンディスク摩耗試験後の表面観察 Examination of surface after ball-on-disk friction test

ボール材 Ball material : A1050
 ボール径 Ball diameter : 6mm
 荷重 Load : 5N
 半径 Radius : 5m
 スピード Speed : 100mm/s
 摺動距離 Rubbing distance : 100m
 基材 Substrate : 超硬合金 Carbide
 無潤滑 No lubrication

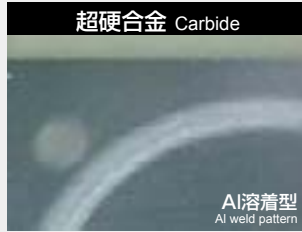

非コーティング超硬に比べ10倍以上の高効率切削加工を実現!!

Achieves 10 times better high-efficiency cutting machining than non coating carbide.

用語説明

Definition of terms

■ ボールオンディスク摩耗試験 Ball-on-disk wear test

固定したボールに荷重を負荷。基材が回転することによる凝着測定方法。
 An adhesion measurement method in which a load is applied to balls mounted on a disk and the substrate is rotated.

■ 新フィルタリング技術 New filtering technology

超平滑な皮膜を生成するための特殊フィルター技術。
 Special filtering technology employed in order to create ultra-smooth coatings.

■ ナノインデンテーション Nano indentation

薄膜の硬度測定に用いる超微小荷重による硬度測定方法。
 A hardness measurement method in which ultra-fine loads are used to measure membrane hardness.

■ GPa
 GN/m²と同一。
 Same as GN/m²

SD5010技術資料 SD5010 Technical Data

01 耐溶着性比較(エアブローとウェット) Comparison of welding resistance (air blow and wet cutting)

ワーク Work material : A5052

<切削条件> Cutting conditions

$v_c=500\text{m/min}$ $f_z=0.15\text{mm/t}$ $a_p \times a_e=2 \times 5\text{mm}$ $OH=25\text{mm}$
 カッター Cutter body : AHU1032R-5 (1枚刃切削 Single insert cutting)

	SD5010	ノンコーティング(WH10) Non coating
エアブロー Air-blow 切削長=45m Cutting length = 45m		
ウェット(水溶性) Wet (Water-soluble agent) 切削長=6m Cutting length = 6m		

SD5010はエアブローでも溶着を抑制!!
 With SD5010, suppresses welding even when cutting with air blower.

Insert : JDET100304R-FA

02 耐溶着性比較(従来品との比較) Comparison of welding resistance (comparison with conventional product)

ワーク Work material : A7075

<切削条件> Cutting conditions

$v_c=500\text{m/min}$ $f_z=0.1\text{mm/t}$ $a_p \times a_e=2 \times 5\text{mm}$ $OH=25\text{mm}$
 カッター Cutter body : AHU1032R-5 (1枚刃切削 Single insert cutting)

	SD5010	従来DLC Conventional DLC
エアブロー Air-blow 切削長=80m (160分切削) Cutting length = 80m (160min. cutting)		

SD5010は耐溶着性に優れる!!
 SD5010 provides superior welding resistance.

03 耐欠損性比較(従来品との比較) Comparison of chipping resistance (comparison with conventional product)

ワーク Work material : A7075

<切削条件> Cutting conditions

$v_c=500\text{m/min}$ $f_z=0.2\text{mm/t}$ $a_p \times a_e=2 \times 5\text{mm}$
 $OH=35\text{mm}$ 工具径 Tool dia. : $\phi 32$ エアブロー Air-blow



従来DLCは $f_z=0.1$ が限界
SD5010は加工能率2倍!!

For conventional DLC product, $f_z=0.1$ is the limit. SD5010 provides twice the machining efficiency.

ラインナップ・標準切削条件表

Line Up, Recommended Cutting Conditions

アルファスーパーエクセレントミニASM形

Super Excellent MINI ASM type



○ 使用インサート Inserts

JDMT07020〇R

刃長5mmを備えた
ショルダー加工用インサート
Insert with 5mm cutting edge length
for shoulder cutting
(APMX=5.0mm)

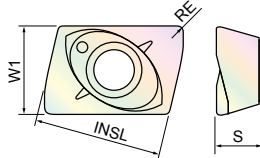

商品コード Item code	精度 Tolerance	在庫材種 Stocked		寸法 (mm)				希望小売価格(円) Suggested retail price (¥)
		DLCコーティング DLC Coating	SD5010	INSL	W1	RE	S	
JDMT070202R	M級 M class	●	●	6.4	4.3	0.2	2.45	1,270
JDMT070204R		●	●	6.4	4.3	0.4	2.45	1,270
JDMT070208R		●	●	6.4	4.3	0.8	2.45	1,270

「SD5010」はSDコーティングを施したインサート用材種です。 SD5010 is an insert material treated with SD Coating.

○ 標準切削条件表 Recommended Cutting Conditions

ASM

<肩削り> Shoulder cutting : $ae=0.5D$

被削材 Work material		φ8	φ10	φ12	φ14	φ16	φ17	φ20	φ21	φ25	φ32
アルミニウム合金展伸材 Expanded aluminum alloy material A5052,A7075等, etc. (ウェット:水溶性) (Wet: Water-soluble agent)	回転数 n (min ⁻¹)	11,900	12,700	10,600	11,400	9,900	9,400	9,500	9,100	7,600	6,000
	切削速度 v_c (m/min)	300	400	400	500	500	500	600	600	600	600
	送り速度 v_f (mm/min)	950	2,040	2,550	2,730	3,180	3,000	3,820	3,640	3,670	3,820
	一刃当の送り量 f_z (mm/t)	0.08	0.08	0.08	0.08	0.08	0.08	0.08	0.08	0.08	0.08
	軸方向切り込み a_p (mm)	2	2	2	2	2	2	2	2	2	2
アルミニウム合金鋳物 Cast aluminum alloy material AC4A,ADC12等, etc. (ウェット:水溶性) (Wet: Water-soluble agent)	回転数 n (min ⁻¹)	9,900	11,100	9,300	9,100	8,000	7,500	8,000	7,600	6,400	5,000
	切削速度 v_c (m/min)	250	350	350	400	400	400	500	500	500	500
	送り速度 v_f (mm/min)	800	1,780	2,230	2,180	2,550	2,400	3,180	3,030	3,060	3,180
	一刃当の送り量 f_z (mm/t)	0.08	0.08	0.08	0.08	0.08	0.08	0.08	0.08	0.08	0.08
	軸方向切り込み a_p (mm)	2	2	2	2	2	2	2	2	2	2
純銅 Pure copper C1100,C1020等, etc. (ウェット:水溶性) (Wet: Water-soluble agent)	回転数 n (min ⁻¹)	9,900	9,500	8,000	6,800	6,000	5,600	4,800	4,500	3,800	3,000
	切削速度 v_c (m/min)	250	300	300	300	300	300	300	300	300	300
	送り速度 v_f (mm/min)	800	1,530	1,910	1,640	1,910	1,800	1,910	1,820	1,830	1,910
	一刃当の送り量 f_z (mm/t)	0.08	0.08	0.08	0.08	0.08	0.08	0.08	0.08	0.08	0.08
	軸方向切り込み a_p (mm)	2	2	2	2	2	2	2	2	2	2

【注意】

- 被削材、加工形状に合わせて、適切なクーラントを使用してください。
- 切削条件は上記表を参考に、加工時の状況に合わせて調整してください。
- 溝切削の場合は送り速度を30%下げて(0.7倍して)ご使用ください。
- L/D=4以上の場合は回転数と送り速度を50%を目安に下げて(0.5倍して)ご使用ください。また、銅加工時の軸方向切り込みは1mm以下として下さい。
- スプラッシュガード付きの機械でご使用ください。ご使用に際しては保護メガネ等の保護具を着用して、安全な環境で作業される事をお願いいたします。
- 上記条件表の回転数まで上がらない機械の場合は使用可能な回転数に設定して、送り速度は f_z 値で計算してください。
- ご使用されるミーリングチャックの許容回転数以内でご使用ください。許容回転数が上記条件表の回転数未満の場合は使用可能な回転数に設定して、送り速度は f_z 値で計算してください。

【Note】

- Use the appropriate coolant for the work material and machining shape.
- The cutting conditions shown in the above table are for reference and should be adjusted according to the actual machining circumstances.
- When cutting grooves, reduce the feed rate by 30% (set it to 0.7 times the value shown above).
- When L/D=4 or higher, reduce rotation speed and feed rate by 50% (set to 0.5 × stated values) as general criteria. In addition, when machining copper, set cutting depth in axial direction to 1mm or less.
- Use on a machine equipped with splashguards. During use, be sure to wear protective equipment such as safety glasses, and always perform work in a safe environment.
- When using a machine that cannot provide the rotation speed shown above, set the highest rotation speed possible and calculate the feed rate using the f_z value.
- Be sure to use this tool at rotation speeds within the acceptable range for the milling chuck being used. If the acceptable rotation speed range is below the rotation speed shown above, set the highest acceptable rotation speed and calculate the feed rate using the f_z value.

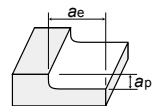

ASM形ホルダとSDコーティング以外のインサートは「MOLDINO NEW PRODUCT NEWS No.1203」をご覧ください。

For ASM-type holders and inserts other than SD Coating inserts are available here: MOLDINO Tool Engineering New Product News No.1203

●印：標準在庫品です。●：Stocked items.

Alpha 超快削エンドミルAHU形

High-Feed Ultra End Mill AHU



○ 使用インサート Inserts

商品コード Item Code	精度 Tolerance Class	在庫材種 Stock	寸法 Size(mm)				希望小売価格 (円) Suggested retail price (¥)
		DLCコーティング DLC Coating	INSL	W1	S	RE	
		SD5010					
JDET100304R-FA	E級 E class	●	11	6.1	3.5	0.4	2,290
JDET150502R-FA		●				0.2	2,600
JDET150504R-FA		●	16	9.12	5	0.4	2,600
JDET150530R-FA		●				3.0	2,600

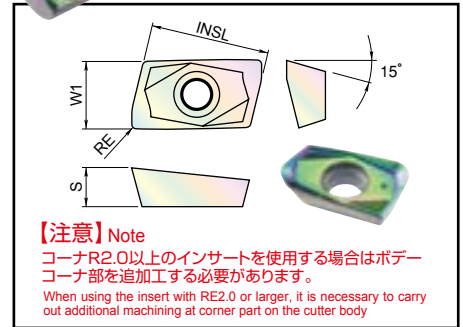

「SD5010」はSDコーティングを施したインサート用材種です。 SD5010 is an insert material treated with SD Coating.

○ 標準切削条件表 Recommended Cutting Conditions

AHU

<肩削り> Shoulder cutting : $ae=0.5D$

被削材 Work material	切削条件 Cutting conditions	AHU/AHUM 10形 type					AHU/AHUB/AHUM 15形 type							
		φ16 (2枚刃) 2 Flutes	φ20 (3枚刃) 3 Flutes	φ25 (4枚刃) 4 Flutes	φ32 (5枚刃) 5 Flutes	φ35 (5枚刃) 5 Flutes	φ25 (2枚刃) 2 Flutes	φ32 (3枚刃) 3 Flutes	φ35 (3枚刃) 3 Flutes	φ40 (4枚刃) 4 Flutes	φ50 (5枚刃) 5 Flutes	φ63 (6枚刃) 6 Flutes	φ80 (7枚刃) 7 Flutes	φ100 (8枚刃) 8 Flutes
アルミニウム合金展伸材 Expanded aluminum alloy material A5052、 A7075等、etc. (エアブロー or ウェット：水溶性) (Air-blow or wet: Water-soluble agent)	回転数 n (min ⁻¹)	15,900	15,900	12,700	11,900	10,910	12,000	9,950	9,090	9,500	7,640	6,060	5,970	4,770
	切削速度 vc (m/min)	800	1,000	1,000	1,200	1,200	950	1,000	1,000	1,200	1,200	1,200	1,500	1,500
	送り速度 vf (mm/min)	4,770	7,150	7,620	8,920	8,180	4,800	5,970	5,450	7,600	7,640	7,270	8,360	7,630
	一刃当の送り量 fz (mm/t)	0.15	0.15	0.15	0.15	0.15	0.2	0.2	0.2	0.2	0.2	0.2	0.2	0.2
	軸方向切り込み ap (mm)	3	3	3	3	3	5	5	5	5	5	5	5	5
アルミニウム合金鋳物 Cast aluminum alloy material AC4A, ADC12等、etc. (エアブロー or ウェット：水溶性) (Air-blow or wet: Water-soluble agent)	回転数 n (min ⁻¹)	12,700	12,700	10,160	9,520	8,730	9,600	7,960	7,270	7,600	6,110	4,850	4,780	3,820
	切削速度 vc (m/min)	640	800	800	960	960	760	800	800	960	960	960	1,200	1,200
	送り速度 vf (mm/min)	3,820	5,720	6,100	7,140	6,550	3,840	4,780	4,360	6,080	6,110	5,820	6,690	6,100
	一刃当の送り量 fz (mm/t)	0.15	0.15	0.15	0.15	0.15	0.2	0.2	0.2	0.2	0.2	0.2	0.2	0.2
	軸方向切り込み ap (mm)	3	3	3	3	3	5	5	5	5	5	5	5	5
純銅 Pure copper C1100, C1020等、etc. (ウェット：水溶性) (Wet: Water-soluble agent)	回転数 n (min ⁻¹)	5,970	4,770	3,820	2,980	2,730	3,820	2,980	2,730	2,390	1,910	1,520	1,190	955
	切削速度 vc (m/min)	300	300	300	300	300	300	300	300	300	300	300	300	300
	送り速度 vf (mm/min)	1,790	2,150	2,290	2,240	2,050	1,530	1,790	1,640	1,910	1,910	1,820	1,670	1,530
	一刃当の送り量 fz (mm/t)	0.15	0.15	0.15	0.15	0.15	0.2	0.2	0.2	0.2	0.2	0.2	0.2	0.2
	軸方向切り込み ap (mm)	3	3	3	3	3	5	5	5	5	5	5	5	5

【注意】

- 被削材、加工形状に合わせて、適切なクーラントを使用してください。
- この切削条件表は切削条件の目安を示すものです。実際の加工では加工形状、目的、使用機械等により条件を調整してください。
- 溝切削の場合は送り速度を30%下げて(0.7倍して)ご使用ください。
- L/D=4以上の場合は回転数と送り速度を60%下げて(0.4倍して)ご使用ください。
- スプラッシュガード付きの機械でご使用ください。ご使用に際しては保護メガネ等の保護具を着用して、安全な環境で作業される事をお願いします。
- 上記条件表の回転数まで上がらない機械の場合は使用可能な回転数に設定して、送り速度は fz 値で計算してください。
- ご使用されるミーリングチャックの許容回転数以内でご使用ください。許容回転数が上記条件表の回転数未満の場合は使用可能な回転数に設定して、送り速度は fz 値で計算してください。

【Note】

- Use the appropriate coolant for the work material and machining shape.
- These conditions are for general guidance; in actual machining conditions adjust the parameters according to your actual machine and work-piece conditions.
- When cutting grooves, reduce the feed rate by 30% (set it to 0.7 times the value shown above).
- When L/D = 4 or higher, reduce the rotation speed and feed rate by 60% (set them to 0.4 times the values shown above).
- Use on a machine equipped with splashguards. During use, be sure to wear protective equipment such as safety glasses, and always perform work in a safe environment.
- When using a machine that cannot provide the rotation speed shown above, set the highest rotation speed possible and calculate the feed rate using the fz value.
- Be sure to use this tool at rotation speeds within the acceptable range for the milling chuck being used. If the acceptable rotation speed range is below the rotation speed shown above, set the highest acceptable rotation speed and calculate the feed rate using the fz value.

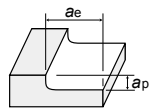

AHU形ホルダとSDコーティング以外のインサートは「MOLDINO NEW PRODUCT NEWS No.1210」をご覧ください。

For AHU-type holders and inserts other than SD Coating inserts are available here: MOLDINO Tool Engineering New Product News No.1210

ラインナップ・標準切削条件表

Line Up, Recommended Cutting Conditions

アルファポリッシュミルVタイプ ASPV形

Polish Mill V type ASPV



○ 使用インサート Inserts

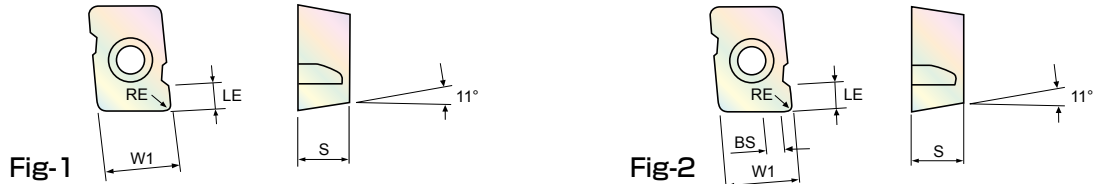

商品コード Item code	精度 Tolerance	在庫材種 Stocked		寸法 Size (mm)					形状 Shape	希望小売価格 (円) Suggested retail price (¥)
		DLCコーティング DLC Coating		W1	BS	S	LE	RE		
		SD5010								
MPHW060302ZEL	H級 H class			6.35	—	3.18	3	0.2	Fig-1	—
MPHW060302ZEL-0.5				6.35	0.5	3.18	3	0.2	Fig-2	—
MPHW060304ZEL				6.35	—	3.18	3	0.4	Fig-1	—
MPHW060304ZEL-0.5				6.35	0.5	3.18	3	0.4	Fig-2	—
MPHW060304ZFL		●		6.35	—	3.18	3	0.4	Fig-1	2,010
MPHW060308ZEL				6.35	—	3.18	3	0.8		—
MPHW060308ZEL-1.5				6.35	1.5	3.18	3	0.8	Fig-2	—
MPHW060308ZFL		●		6.35	—	3.18	3	0.8	Fig-1	2,010
MPHW060320ZEL				6.35	—	3.18	3	2.0		—
MPNW060308ZEL		N級 N class			6.35	—	3.18	3		0.8
MPNW060320ZEL				6.35	—	3.18	3	2.0	—	

「SD5010」はSDコーティングを施したインサート用材種です。 SD5010 is an insert material treated with SD Coating.

○ 標準切削条件表 Recommended Cutting Conditions ASPV

底面仕上げ標準切削条件 Cutting conditions for bottom finishing : $a_e = 0.5D \sim 0.7D$

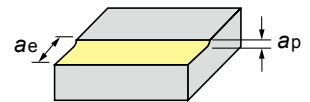

被削材 Work material		φ16	φ18	φ20	φ22	φ25	φ28	φ30	φ32	φ35	φ40	φ50	φ63
		2枚刃 ft.	2枚刃 ft.	3枚刃 ft.	3枚刃 ft.	4枚刃 ft.	4枚刃 ft.	4枚刃 ft.	5枚刃 ft.	5枚刃 ft.	6枚刃 ft.	7枚刃 ft.	8枚刃 ft.
アルミニウム合金展伸材 Expanded aluminum alloy material A5052, A7075等, etc. (エアブローorウェット:水溶性) (Air-blow or wet: Water-soluble agent)	回転数 n (min ⁻¹)	15,900	15,900	15,900	15,900	15,300	13,640	12,730	11,940	10,910	9,550	7,640	6,060
	切削速度 v_c (m/min)	800	900	1,000	1,100	1,200	1,200	1,200	1,200	1,200	1,200	1,200	1,200
	送り速度 v_f (mm/min)	3,180	3,180	4,770	4,770	6,120	5,460	5,090	4,780	4,360	4,580	3,210	2,910
	一刃当の送り量 f_z (mm/t)	0.1	0.1	0.1	0.1	0.1	0.1	0.1	0.08	0.08	0.08	0.06	0.06
	軸方向切り込み a_p (mm)	0.2	0.2	0.2	0.2	0.2	0.2	0.2	0.2	0.2	0.2	0.2	0.2
アルミニウム合金鋳物 Cast aluminum alloy material AC4A, ADC12等, etc. (エアブローorウェット:水溶性) (Air-blow or wet: Water-soluble agent)	回転数 n (min ⁻¹)	12,700	12,700	12,700	12,700	12,200	10,900	10,190	9,550	8,730	7,640	6,110	4,850
	切削速度 v_c (m/min)	640	720	800	880	960	960	960	960	960	960	960	960
	送り速度 v_f (mm/min)	2,540	2,540	3,810	3,810	4,900	4,360	4,080	3,820	3,490	3,670	2,570	2,330
	一刃当の送り量 f_z (mm/t)	0.1	0.1	0.1	0.1	0.1	0.1	0.1	0.08	0.08	0.08	0.06	0.06
	軸方向切り込み a_p (mm)	0.2	0.2	0.2	0.2	0.2	0.2	0.2	0.2	0.2	0.2	0.2	0.2
純銅 Pure copper C1100, C1020等, etc. (ウェット:水溶性) (Wet: Water-soluble agent)	回転数 n (min ⁻¹)	5,970	5,300	4,770	4,340	3,820	3,410	3,180	2,980	2,730	2,390	1,910	1,520
	切削速度 v_c (m/min)	300	300	300	300	300	300	300	300	300	300	300	300
	送り速度 v_f (mm/min)	1,190	1,060	1,430	1,300	1,530	1,360	1,270	1,190	1,090	1,150	800	730
	一刃当の送り量 f_z (mm/t)	0.1	0.1	0.1	0.1	0.1	0.1	0.1	0.08	0.08	0.08	0.06	0.06
	軸方向切り込み a_p (mm)	0.2	0.2	0.2	0.2	0.2	0.2	0.2	0.2	0.2	0.2	0.2	0.2

●印：標準在庫品です。 ●： Stocked items. 無印：受注生産品です。 No Mark： Manufactured upon request only.

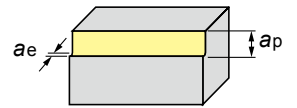

側面仕上げ標準切削条件 Cutting conditions for side finishing : $a_e=0.2\text{mm}$ 以下 $a_e \leq 0.2\text{mm}$

被削材 Work material		$\phi 16$	$\phi 18$	$\phi 20$	$\phi 22$	$\phi 25$	$\phi 28$	$\phi 30$	$\phi 32$	$\phi 35$	$\phi 40$	$\phi 50$	$\phi 63$
		2枚刃 ft.	2枚刃 ft.	3枚刃 ft.	3枚刃 ft.	4枚刃 ft.	4枚刃 ft.	4枚刃 ft.	5枚刃 ft.	5枚刃 ft.	6枚刃 ft.	7枚刃 ft.	8枚刃 ft.
アルミニウム合金展伸材 Expanded aluminum alloy material A5052,A7075等, etc. (エアブローorウェット:水溶性) (Air-blow or wet: Water-soluble agent)	回転数 n (min^{-1})	15,900	15,900	15,900	15,900	15,300	13,640	12,730	11,940	10,910	9,550	7,640	6,060
	切削速度 v_c (m/min)	800	900	1,000	1,100	1,200	1,200	1,200	1,200	1,200	1,200	1,200	1,200
	送り速度 v_f (mm/min)	4,770	4,770	7,160	7,160	9,180	8,180	7,640	8,960	8,180	10,300	10,700	9,700
	一刃当の送り量 f_z (mm/t)	0.15	0.15	0.15	0.15	0.15	0.15	0.15	0.15	0.15	0.15	0.18	0.2
	軸方向切り込み a_p (mm)	2	2	2	2	2	2	2	2	2	2	2	2
アルミニウム合金鋳物 Cast aluminum alloy material AC4A,ADC12等, etc. (エアブローorウェット:水溶性) (Air-blow or wet: Water-soluble agent)	回転数 n (min^{-1})	12,700	12,700	12,700	12,700	12,200	10,900	10,190	9,550	8,730	7,640	6,110	4,850
	切削速度 v_c (m/min)	640	720	800	880	960	960	960	960	960	960	960	960
	送り速度 v_f (mm/min)	3,810	3,810	5,720	5,720	7,320	6,540	6,100	7,160	6,550	8,250	8,550	7,760
	一刃当の送り量 f_z (mm/t)	0.15	0.15	0.15	0.15	0.15	0.15	0.15	0.15	0.15	0.15	0.18	0.2
	軸方向切り込み a_p (mm)	2	2	2	2	2	2	2	2	2	2	2	2
純銅 Pure copper C1100,C1020等, etc. (ウェット:水溶性) (Wet: Water-soluble agent)	回転数 n (min^{-1})	5,970	5,300	4,770	4,340	3,820	3,410	3,180	2,980	2,730	2,390	1,910	1,520
	切削速度 v_c (m/min)	300	300	300	300	300	300	300	300	300	300	300	300
	送り速度 v_f (mm/min)	1,790	1,590	2,150	1,950	2,290	2,050	1,910	2,240	2,730	2,870	3,340	3,040
	一刃当の送り量 f_z (mm/t)	0.15	0.15	0.15	0.15	0.15	0.15	0.15	0.15	0.15	0.2	0.2	0.25
	軸方向切り込み a_p (mm)	2	2	2	2	2	2	2	2	2	2	2	2

バッチカル荒加工標準切削条件 Cutting conditions for vertical roughing

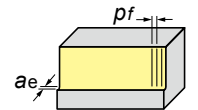

被削材 Work material		$\phi 16$	$\phi 18$	$\phi 20$	$\phi 22$	$\phi 25$	$\phi 28$	$\phi 30$	$\phi 32$	$\phi 35$	$\phi 40$	$\phi 50$	$\phi 63$
		2枚刃 ft.	2枚刃 ft.	3枚刃 ft.	3枚刃 ft.	4枚刃 ft.	4枚刃 ft.	4枚刃 ft.	5枚刃 ft.	5枚刃 ft.	6枚刃 ft.	7枚刃 ft.	8枚刃 ft.
アルミニウム合金展伸材 Expanded aluminum alloy material A5052,A7075等, etc. (エアブローorウェット:水溶性) (Air-blow or wet: Water-soluble agent)	回転数 n (min^{-1})	15,900	15,900	15,900	15,900	15,300	13,640	12,730	11,940	10,910	9,550	7,640	6,060
	切削速度 v_c (m/min)	800	900	1,000	1,100	1,200	1,200	1,200	1,200	1,200	1,200	1,200	1,200
	送り速度 v_f (mm/min)	4,770	4,770	7,160	7,160	9,180	8,180	7,640	8,960	8,180	8,600	8,020	7,270
	一刃当の送り量 f_z (mm/t)	0.15	0.15	0.15	0.15	0.15	0.15	0.15	0.15	0.15	0.15	0.15	0.15
	ピッチフィード p_f (mm)	3.5	4	4	4	4.5	4.5	5	5	5.5	6	6.5	7
	軸方向切り込み a_p (mm)	4	4	4	4	4	4	4	4	4	4	4	4
アルミニウム合金鋳物 Cast aluminum alloy material AC4A,ADC12等, etc. (エアブローorウェット:水溶性) (Air-blow or wet: Water-soluble agent)	回転数 n (min^{-1})	12,700	12,700	12,700	12,700	12,200	10,900	10,190	9,550	8,730	7,640	6,110	4,850
	切削速度 v_c (m/min)	640	720	800	880	960	960	960	960	960	960	960	960
	送り速度 v_f (mm/min)	3,810	3,810	5,720	5,720	7,320	6,540	6,100	7,160	6,550	6,880	6,420	5,820
	一刃当の送り量 f_z (mm/t)	0.15	0.15	0.15	0.15	0.15	0.15	0.15	0.15	0.15	0.15	0.15	0.15
	ピッチフィード p_f (mm)	3.5	4	4	4	4.5	4.5	5	5	5.5	6	6.5	7
	軸方向切り込み a_p (mm)	4	4	4	4	4	4	4	4	4	4	4	4
純銅 Pure copper C1100,C1020等, etc. (ウェット:水溶性) (Wet: Water-soluble agent)	回転数 n (min^{-1})	5,970	5,300	4,770	4,340	3,820	3,410	3,180	2,980	2,730	2,390	1,910	1,520
	切削速度 v_c (m/min)	300	300	300	300	300	300	300	300	300	300	300	300
	送り速度 v_f (mm/min)	1,790	1,590	2,150	1,950	2,290	2,050	1,910	2,240	2,050	2,150	2,000	1,820
	一刃当の送り量 f_z (mm/t)	0.15	0.15	0.15	0.15	0.15	0.15	0.15	0.15	0.15	0.15	0.15	0.15
	ピッチフィード p_f (mm)	3.5	4	4	4	4.5	4.5	5	5	5.5	6	6.5	7
	軸方向切り込み a_p (mm)	4	4	4	4	4	4	4	4	4	4	4	4

- [注意]**
- この切削条件表は切削条件の目安を示すものです。実際の加工では加工形状、目的、使用機械等により条件を調整してください。
 - L/D=4以上の場合は回転数と送り速度を60%下げて(0.4倍して)ご使用ください。
 - スプラッシュガード付きの機械でご使用ください。ご使用に際しては保護めがね等の保護具を着用して、安全な環境で作業される事をお願いいたします。
 - 上記条件表の回転数まで上がらない機械の場合は使用可能な回転数に設定して、送り速度は f_z 値で計算してください。
 - ご使用されるミーリングチャックの許容回転数以内でご使用ください。許容回転数が上記条件表の回転数未満の場合は使用可能な回転数に設定して、送り速度は f_z 値で計算してください。

- [Note]**
- These conditions are for general guidance; in actual machining conditions adjust the parameters according to your actual machine and work-piece conditions.
 - When L/D = 4 or higher, reduce the rotation speed and feed rate by 60% (set them to 0.4 times the values shown above).
 - Use on a machine equipped with splashguards. During use, be sure to wear protective equipment such as safety glasses, and always perform work in a safe environment.
 - When using a machine that cannot provide the rotation speed shown above, set the highest rotation speed possible and calculate the feed rate using the f_z value.
 - Be sure to use this tool at rotation speeds within the acceptable range for the milling chuck being used. If the acceptable rotation speed range is below the rotation speed shown above, set the highest acceptable rotation speed and calculate the feed rate using the f_z value.

ASPV形ホルダとSDコーティング以外のインサートは「MOLDINO NEW PRODUCT NEWS No.1211」をご覧ください。

For ASPV-type holders and inserts other than SD Coating inserts are available here: MOLDINO Tool Engineering New Product News No.1211

エポック SD(S-DLC) エンドミルシリーズ

Epoch SD(S-DLC) End Mill series

高い耐溶着性能!! アルミ合金・銅の加工に最適!!

High welding resistance performance. Ideal for machining aluminum alloys and copper.

【切削条件】

φ6×2枚刃
エポックSD(S-DLC)スクエア
(EPAS2060-SD)
溝切削
回転数： $n=12,000\text{min}^{-1}$
($v_c=226\text{m/min}$)
送り： $v_f=540\text{mm/min}$
($f_z=0.023\text{mm/t}$)
切込み： $a_p \times a_e=6\text{mm} \times 6\text{mm}$

【Cutting conditions】

φ6×2flutes
Epoch SD(S-DLC)
Square
Slotting
Revolution： $n=12,000\text{min}^{-1}$
($v_c=226\text{m/min}$)
Feed rate： $v_f=540\text{mm/min}$
($f_z=0.023\text{mm/t}$)
Depth of cut： $a_p \times a_e=6\text{mm} \times 6\text{mm}$

ノンコーティング
Non coating

従来DLC(A)
Conventional DLC (A)

従来DLC(B)
Conventional DLC (B)

SD(S-DLC)
コーティング
SD(S-DLC) Coating

アルミ合金
Aluminium alloy
A5052
乾式切削
Dry cutting

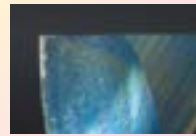
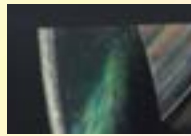

アルミ合金
Aluminium alloy
A7075
乾式切削
Dry cutting

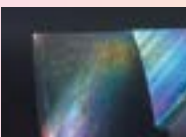
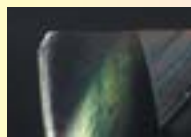

アルミ合金
Aluminium alloy
AC4A
湿式切削
Wet cutting

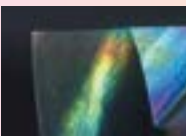
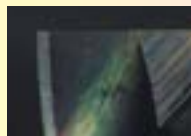
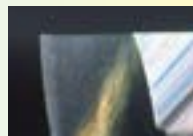

銅合金
Copper
C1100
湿式切削
Wet cutting

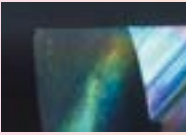
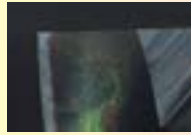

アクリル樹脂
Acrylic resin
湿式切削
Wet cutting

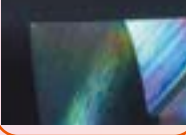
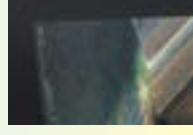

優れた耐摩耗性と高品位な加工面!!

Superior wear resistance and high-grade machined surface

●アクリル樹脂の底面仕上げ切削 Bottom finish cutting in acrylic resin

【切削条件】

R3×2枚刃
エポックSD(S-DLC)ボール (EPAB2060-SD)
底面切削
被削材：アクリル樹脂
回転数： $n=20,000\text{min}^{-1}$ ($v_c=377\text{m/min}$)
送り： $v_f=1,600\text{mm/min}$ ($f_z=0.04\text{mm/t}$)
切込み： $a_p \times a_e=0.1 \times 0.1\text{mm}$
水溶性切削液

【Cutting conditions】

R3×2Flutes Epoch SD(S-DLC) Ball (EPAB2060-SD)
Bottom Cutting
Work material：Acrylic resin
Revolution： $n=20,000\text{min}^{-1}$ ($v_c=377\text{m/min}$)
Feed rate： $v_f=1,600\text{mm/min}$ ($f_z=0.04\text{mm/t}$)
Depth of cut： $a_p \times a_e=0.1 \times 0.1\text{mm}$
Water-base coolant

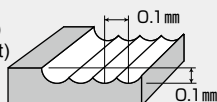

切削長 $L=75\text{m}$
Cutting Length

ノンコーティング
Non coating

SD(S-DLC)コーティング
SD(S-DLC) Coating

工具摩耗
Tool wear



摩耗進行あり
Wear progress exists



摩耗小さい
Small wear

加工面品位
Machined surface grade

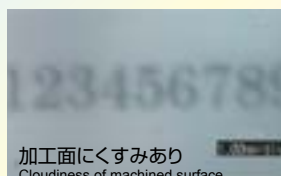

加工面にくすみあり
Cloudiness of machined surface

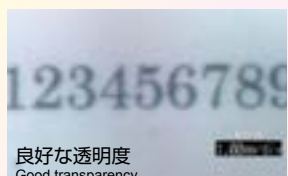

良好な透明度
Good transparency

エポック SD(S-DLC) デープスクエア

Epoch SD(S-DLC) Deep Square

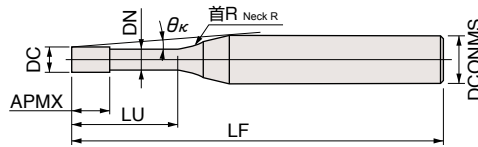
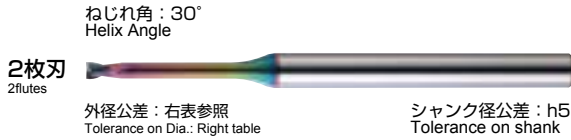

(mm)	
外径DC Tool dia.	外径公差 Tolerance on Dia.
DC ≤ φ0.5	0 -0.007
φ0.5 < DC < φ1	0 -0.010
φ1 ≤ DC	0 -0.015

EPDS2000-SD

商品コード Item code	在庫 Stock	寸法 Size (mm)							干渉角度 Interference angle (°) θ_k	勾配角に対する実有効首下長 Effective under neck length with respect to draft angle					希望小売 価格 (円) Suggested retail price (¥)
		外径 Tool dia.	首下長 Under neck length	刃長 Flute length	首径 Neck dia.	全長 Overall length	シャンク径 Shank dia.	首R Neck R		0.5°	1°	1.5°	2°	3°	
		DC	LU	APMX	DN	LF	DCONMS								
EPDS2005-2-SD	●		2						9.64	2.89	3.18	3.44	3.69	4.14	7,920
EPDS2005-4-SD	●	0.5	4	0.75	0.47	50	4	10	8.1	5.08	5.48	5.82	6.12	6.67	7,920
EPDS2005-6-SD	●		6						6.98	7.27	7.72	8.12	8.47	9.09	7,920
EPDS2006-2-SD	●		2						9.59	2.89	3.18	3.44	3.69	4.14	7,920
EPDS2006-4-SD	●	0.6	4	0.9	0.57	50	4	10	8.02	5.08	5.48	5.82	6.12	6.67	7,920
EPDS2006-6-SD	●		6						6.9	7.24	7.72	8.12	8.47	9.09	7,920
EPDS2008-4-SD	●		4						7.86	5.08	5.48	5.82	6.12	6.67	7,920
EPDS2008-6-SD	●	0.8	6	1.2	0.77	50	4	10	6.72	7.24	7.72	8.12	8.47	9.09	7,920
EPDS2008-8-SD	●		8						5.86	9.38	9.93	10.37	10.76	11.45	7,920
EPDS2010-4-SD	●		4			50			7.67	5.13	5.52	5.85	6.15	6.69	7,920
EPDS2010-8-SD	●	1	8	1.5	0.96	50	4	10	5.66	9.42	9.95	10.4	10.78	11.46	7,920
EPDS2010-12-SD	●		12			55			4.48	13.66	14.3	14.82	15.28	16.06	7,920
EPDS2015-6-SD	●		6			50			5.94	7.37	7.81	8.19	8.54	9.15	7,920
EPDS2015-12-SD	●	1.5	12	2.25	1.44	55	4	10	3.97	13.72	14.35	14.86	15.31	16.11	7,920
EPDS2015-18-SD	●		18			60			2.98	20.01	20.77	21.38	21.9	干渉なし	7,920
EPDS2020-8-SD	●		8			50			4.44	9.56	10.06	10.48	10.86	11.53	7,920
EPDS2020-16-SD	●	2	16	3	1.92	55	4	10	2.75	17.97	18.68	19.25	19.75	干渉なし	7,920
EPDS2020-24-SD	●		24			60			1.99	26.3	27.16	27.84	干渉なし	干渉なし	7,920
EPDS2030-12-SD	●		12			60			4.44	13.89	14.48	14.97	15.4	16.3	11,150
EPDS2030-24-SD	●	3	24	4.5	2.88	65	6	10	2.75	26.39	27.22	27.89	29.05	干渉なし	11,150
EPDS2030-36-SD	●		36			80			1.99	38.79	39.81	41.38	干渉なし	干渉なし	14,890
EPDS2040-16-SD	●		16			60			2.72	18.14	18.81	19.36	19.84	干渉なし	11,900
EPDS2040-32-SD	●	4	32	6	3.85	80	6	10	1.55	34.72	35.66	36.89	干渉なし	干渉なし	11,900
EPDS2040-48-SD	●		48			90			1.08	51.18	52.67	干渉なし	干渉なし	干渉なし	15,430

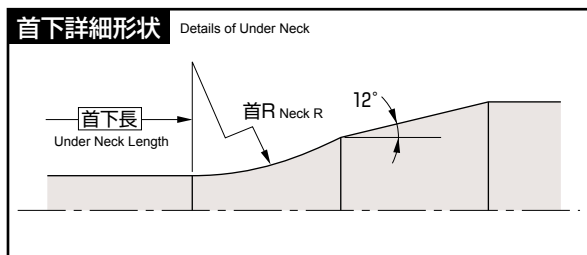

【注意】

加工物に勾配がついている場合、干渉領域は、首下長よりも長くなります。それぞれの勾配角に対する実有効首下長をご参照ください。
また、工具が加工物に干渉する角度を干渉角度 θ_k で表示していますので合わせてご参照ください。

【Note】

If the workpiece has draft angle, the interference length will be longer than the under-neck length. Please refer to the effective under-neck length for the various draft angles.
In addition, the angle at which the tool will interfere with the workpiece is shown as the "interference angle θ_k ", and should also be referred to.

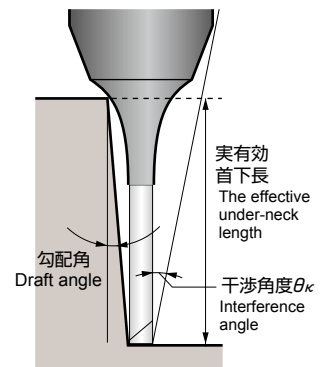

ラインナップ・標準切削条件表

Line Up, Recommended Cutting Conditions

標準切削条件表 Recommended Cutting Conditions EPDS-SD

<溝切削> Slotting

商品コード Item code	外径DC Tool dia. (mm)	首下長LU Under neck length (mm)	軸方向切り込み量 Axial direction cutting depth (mm)	1		2		3		4	
				回転数 n min ⁻¹	送り速度 v_f mm/min	回転数 n min ⁻¹	送り速度 v_f mm/min	回転数 n min ⁻¹	送り速度 v_f mm/min	回転数 n min ⁻¹	送り速度 v_f mm/min
				アルミニウム合金展伸材 A5052,A7075等, etc. Expanded aluminum alloy material		アルミニウム合金鋳物 AC4A,ADC12等, etc. Cast aluminum alloy material		銅合金 C1100等, etc. Pure copper		樹脂 アクリル等 Resin, Acrylic, etc.	
EPDS2005-2-SD	0.5	2	0.15	50,000	1,180	50,000	1,150	38,400	850	38,400	1,280
EPDS2005-4-SD	0.5	4	0.09	50,000	1,080	46,660	980	34,560	700	34,560	1,050
EPDS2005-6-SD	0.5	6	0.06	46,080	860	41,470	760	30,720	540	30,720	810
EPDS2006-2-SD	0.6	2	0.18	50,000	1,680	50,000	1,535	38,400	1,210	38,400	1,820
EPDS2006-4-SD	0.6	4	0.11	50,000	1,535	46,660	1,390	34,560	995	34,560	1,490
EPDS2006-6-SD	0.6	6	0.06	50,000	1,535	46,660	1,390	34,560	995	34,560	1,490
EPDS2008-4-SD	0.8	4	0.24	50,000	1,680	50,000	1,535	38,400	1,210	38,400	1,820
EPDS2008-6-SD	0.8	6	0.14	50,000	1,535	46,660	1,390	34,560	995	34,560	1,490
EPDS2008-8-SD	0.8	8	0.09	50,000	1,535	46,660	1,390	34,560	995	34,560	1,490
EPDS2010-4-SD	1	4	0.3	50,000	2,500	46,660	2,280	34,560	1,628	34,560	2,440
EPDS2010-8-SD	1	8	0.17	46,650	2,140	41,990	1,880	31,100	1,340	31,100	2,010
EPDS2010-12-SD	1	12	0.11	41,480	1,670	37,330	1,460	27,650	1,045	27,650	1,570
EPDS2015-6-SD	1.5	6	0.45	40,320	2,030	36,290	1,780	26,880	1,270	26,880	1,910
EPDS2015-12-SD	1.5	12	0.25	36,290	1,670	32,660	1,460	24,190	1,045	24,190	1,570
EPDS2015-18-SD	1.5	18	0.16	32,250	1,300	29,030	1,130	21,500	810	21,500	1,220
EPDS2020-8-SD	2	8	0.6	30,240	2,030	27,220	1,780	20,160	1,270	20,160	1,910
EPDS2020-16-SD	2	16	0.35	27,150	1,670	24,440	1,460	18,100	1,045	18,100	1,570
EPDS2020-24-SD	2	24	0.21	24,200	1,300	21,780	1,130	16,130	810	16,130	1,220
EPDS2030-12-SD	3	12	0.9	23,040	1,940	20,740	1,690	15,360	1,210	15,360	1,820
EPDS2030-24-SD	3	24	0.36	20,730	1,600	18,660	1,390	13,820	995	13,820	1,490
EPDS2030-36-SD	3	36	0.26	18,450	1,400	16,610	1,230	12,300	880	12,300	1,320
EPDS2040-16-SD	4	16	1.2	17,250	3,680	15,530	3,220	11,500	2,300	11,500	2,300
EPDS2040-32-SD	4	32	0.64	15,530	2,980	13,970	2,600	10,350	1,860	10,350	1,860
EPDS2040-48-SD	4	48	0.35	13,650	2,640	12,290	2,300	9,100	1,640	9,100	1,640

- 【備考】**
- ①樹脂の材質によってはエアブローを推奨致します。
 - ②この標準切削条件表は切削条件の目安を示したものです。実際の加工形状・使用機械・加工目的により条件を調整してください。
 - ③機械の回転数が足りない場合は、回転数と送り速度を同じ比率で下げてください。

- 【Note】**
- ① An air blower is recommended for some resin materials.
 - ② The cutting conditions shown in the table above are reference cutting conditions, and should be adjusted according to the actual shape to be machined, the machine used, and purpose for machining.
 - ③ If the machine rotation speed is insufficient, reduce the rotation speed and feed rate by the same ratio.

a_p : 軸方向切り込み量 (mm)
DC : 外径 (mm)
 a_p : Axial direction cutting depth (mm)
DC : Outer diameter (mm)

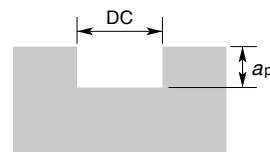

<側面仕上げ切削> Side Finishing

被削材 Work material	1		2	
	アルミニウム合金展伸材 A5052,A7075等, etc. Expanded aluminum alloy material		樹脂 アクリル等 Resin, Acrylic, etc.	
外径DC Tool dia. (mm)	回転数 n min ⁻¹	送り速度 v_f mm/min	回転数 n min ⁻¹	送り速度 v_f mm/min
0.5	50,000	2,000	50,000	2,000
0.6	48,000	1,920	48,000	1,920
0.8	44,000	2,200	44,000	2,200
1	40,000	2,400	40,000	2,400
1.5	34,000	2,400	34,000	2,400
2	30,000	2,400	30,000	2,400
3	26,000	2,080	26,000	2,080
4	24,000	1,920	24,000	1,920

切り込み量 Depth of Cut (mm)

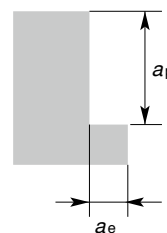

$a_p \leq 1D$
 $a_e \leq 0.02\text{mm} \sim 0.05\text{mm}$

エポック SD(S-DLC) ディープボール

Epoch SD(S-DLC) Deep Ball

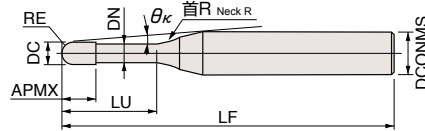

(mm)	
ボール半径 RE	RE精度 Tolerance on RE
RE ≤ 0.25	±0.003
0.25 < RE	±0.005

EPDB2○○○-○○○-SD

商品コード Item code	在庫 Stock	寸法 Size (mm)								干渉角度 Interference angle (°) θκ	勾配角に対する実有効首下長 Effective under neck length with respect to draft angle					希望小売 価格(円) Suggested retail price (¥)
		ボール半径 Ball radius RE	外径 Tool dia. DC	首下長 Under neck length LU	刃長 Flute length APMX	首径 Neck dia. DN	全長 Overall length LF	シャック径 Shank dia. DCONMS	首R Neck R		0.5°	1°	1.5°	2°	3°	
											0.5°	1°	1.5°	2°	3°	
EPDB2002-0.4-SD	●	0.1	0.2	0.4	0.15	0.17	50	4	1	11.54	0.59	0.61	0.63	0.66	0.7	19,820
EPDB2002-0.6-SD	●			0.6						11.3	0.8	0.83	0.86	0.88	0.93	19,820
EPDB2002-1-SD	●			1						10.86	1.22	1.26	1.3	1.33	1.39	19,820
EPDB2003-0.5-SD	●	0.15	0.3	0.5	0.25	0.27	50	4	2	11.47	0.78	0.82	0.86	0.9	0.98	19,820
EPDB2003-1-SD	●			1						10.89	1.31	1.38	1.43	1.49	1.59	19,820
EPDB2003-1.5-SD	●			1.5						10.36	1.84	1.92	1.99	2.06	2.18	21,420
EPDB2004-1-SD	●	0.2	0.4	1	0.3	0.37	50	4	2	10.91	1.31	1.37	1.43	1.48	1.58	13,510
EPDB2004-1.5-SD	●			1.5						10.37	1.84	1.92	1.99	2.06	2.17	13,720
EPDB2004-2-SD	●			2						9.88	2.36	2.46	2.54	2.62	2.75	14,250
EPDB2005-2-SD	●	0.25	0.5	2	0.35	0.47	50	4	10	9.88	2.86	3.14	3.39	3.62	4.06	13,510
EPDB2005-4-SD	●			4						8.27	5.06	5.45	5.78	6.08	6.61	13,510
EPDB2005-6-SD	●			6						7.1	7.23	7.69	8.08	8.43	9.05	14,250
EPDB2006-2-SD	●	0.3	0.6	2	0.4	0.57	50	4	10	9.88	2.86	3.13	3.38	3.61	4.04	10,320
EPDB2006-4-SD	●			4						8.22	5.06	5.44	5.77	6.07	6.6	11,150
EPDB2006-6-SD	●			6						7.04	7.22	7.69	8.08	8.42	9.04	11,150
EPDB2008-4-SD	●	0.4	0.8	4	0.5	0.77	50	4	10	8.14	5.05	5.43	5.75	6.05	6.58	11,150
EPDB2008-6-SD	●			6						6.92	7.21	7.68	8.06	8.41	9.02	11,150
EPDB2008-8-SD	●			8						6.01	9.36	9.89	10.33	10.71	11.38	11,150
EPDB2010-4-SD	●	0.5	1	4	0.8	0.96	50	4	10	8.02	5.09	5.45	5.77	6.06	6.58	9,830
EPDB2010-8-SD	●			8						5.85	9.39	9.91	10.34	10.72	11.38	10,640
EPDB2010-12-SD	●			12						4.6	13.63	14.26	14.78	15.22	15.99	10,640
EPDB2015-6-SD	●	0.75	1.5	6	1.35	1.44	50	4	10	6.33	7.31	7.73	8.09	8.42	9.01	10,120
EPDB2015-12-SD	●			12						4.14	13.68	14.29	14.79	15.23	15.98	12,650
EPDB2015-18-SD	●			18						3.08	19.97	20.72	21.32	21.84	23.83	12,650
EPDB2020-8-SD	●	1	2	8	1.7	1.92	50	4	10	4.81	9.5	9.97	10.37	10.73	11.37	10,640
EPDB2020-16-SD	●			16						2.88	17.92	18.61	19.17	19.65	干渉なし	10,640
EPDB2020-24-SD	●			24						2.06	26.26	27.11	27.77	28.75	干渉なし	14,250
EPDB2030-12-SD	●	1.5	3	12	2.5	2.88	55	6	10	4.81	13.82	14.36	14.83	15.24	15.96	13,820
EPDB2030-24-SD	●			24						2.88	26.33	27.14	27.79	28.76	干渉なし	13,820
EPDB2030-36-SD	●			36						2.06	38.74	39.74	41.17	43.12	干渉なし	17,570
EPDB2040-16-SD	●	2	4	16	3	3.9	60	6	10	3.03	17.93	18.58	19.11	19.58	20.91	12,220
EPDB2040-32-SD	●			32						1.64	34.56	35.5	36.48	干渉なし	干渉なし	15,860
EPDB2040-48-SD	●			48						1.13	51.05	52.37	干渉なし	干渉なし	干渉なし	20,680
EPDB2050-20-SD	●	2.5	5	20	3.5	4.9	65	6	10	1.38	22.09	22.81	干渉なし	干渉なし	干渉なし	20,760
EPDB2050-40-SD	●			40						0.71	42.8	干渉なし	干渉なし	干渉なし	干渉なし	22,330

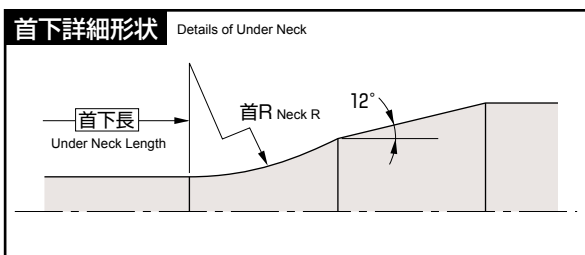

【注意】

加工物に勾配がついている場合、干渉領域は、首下長さよりも長くなります。それぞれの勾配角に対する実有効首下長をご参照ください。また、工具が加工物に干渉する角度を干渉角度 θ_{κ} で表示していますので合わせてご参照ください。

【Note】

If the workpiece has draft angle, the interference length will be longer than the under-neck length. Please refer to the effective under-neck length for the various draft angles. In addition, the angle at which the tool will interfere with the workpiece is shown as the "interference angle θ_{κ} ", and should also be referred to.

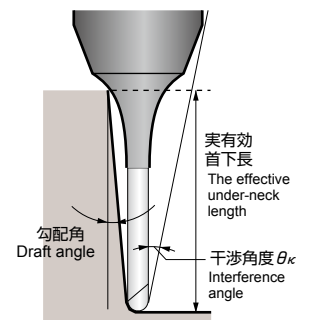

●印：標準在庫品です。 ●：Stocked items. 干渉なし：No interference

ラインナップ・標準切削条件表

Line Up, Recommended Cutting Conditions

標準切削条件表 Recommended Cutting Conditions EPDB-SD

<溝切削> Slotting

商品コード Item code	ボール半径RE Ball radius (mm)	外径DC Tool dia. (mm)	首下長LU Under neck length (mm)	軸方向切り込み量 Axial direction cutting depth (mm)	1		2		3		4	
					被削材 Work material	回転数 n min ⁻¹	送り速度 v_f mm/min	回転数 n min ⁻¹	送り速度 v_f mm/min	回転数 n min ⁻¹	送り速度 v_f mm/min	回転数 n min ⁻¹
					アルミニウム合金展伸材 A5052,A7075等, etc. Expanded aluminum alloy material			アルミニウム合金鋳物 AC4A,ADC12等, etc. Cast aluminum alloy material		銅合金 C1100等, etc. Pure copper		樹脂 アクリル等 Resin, Acrylic, etc.
EPDB2002-0.4-SD	0.1	0.2	0.4	0.03	50,000	500	50,000	500	50,000	500	50,000	750
EPDB2002-0.6-SD	0.1	0.2	0.6	0.025	50,000	450	50,000	450	50,000	450	50,000	680
EPDB2002-1-SD	0.1	0.2	1	0.017	50,000	450	50,000	450	50,000	450	50,000	680
EPDB2003-0.5-SD	0.15	0.3	0.5	0.033	50,000	800	50,000	800	50,000	800	50,000	1,200
EPDB2003-1-SD	0.15	0.3	1	0.026	50,000	700	50,000	700	50,000	700	50,000	1,050
EPDB2003-1.5-SD	0.15	0.3	1.5	0.02	50,000	600	50,000	600	50,000	600	50,000	900
EPDB2004-1-SD	0.2	0.4	1	0.05	50,000	980	50,000	980	50,000	980	47,800	1,470
EPDB2004-1.5-SD	0.2	0.4	1.5	0.04	50,000	840	50,000	840	50,000	840	43,000	1,260
EPDB2004-2-SD	0.2	0.4	2	0.034	50,000	700	50,000	700	47,700	700	38,200	1,050
EPDB2005-2-SD	0.25	0.5	2	0.1	50,000	1,000	50,000	1,000	48,000	960	38,400	1,280
EPDB2005-4-SD	0.25	0.5	4	0.06	50,000	900	50,000	900	43,200	780	34,560	1,050
EPDB2005-6-SD	0.25	0.5	6	0.03	50,000	850	50,000	850	38,400	650	30,720	810
EPDB2006-2-SD	0.3	0.6	2	0.12	50,000	1,500	50,000	1,500	48,000	1,440	38,400	1,820
EPDB2006-4-SD	0.3	0.6	4	0.07	50,000	1,420	50,000	1,420	43,200	1,230	34,560	1,490
EPDB2006-6-SD	0.3	0.6	6	0.04	50,000	1,350	50,000	1,350	43,200	1,170	34,560	1,490
EPDB2008-4-SD	0.4	0.8	4	0.16	50,000	1,800	50,000	1,800	48,000	1,730	38,400	1,820
EPDB2008-6-SD	0.4	0.8	6	0.1	50,000	1,620	50,000	1,620	43,200	1,400	34,560	1,490
EPDB2008-8-SD	0.4	0.8	8	0.05	50,000	1,610	50,000	1,610	38,400	1,240	34,560	1,490
EPDB2010-4-SD	0.5	1	4	0.2	50,000	2,500	50,000	2,500	43,200	2,160	34,560	2,440
EPDB2010-8-SD	0.5	1	8	0.12	50,000	2,250	50,000	2,250	38,880	1,750	31,100	2,010
EPDB2010-12-SD	0.5	1	12	0.06	50,000	2,130	46,660	1,980	34,560	1,470	27,650	1,570
EPDB2015-6-SD	0.75	1.5	6	0.3	50,000	3,300	45,360	3,000	33,600	2,220	26,880	1,910
EPDB2015-12-SD	0.75	1.5	12	0.18	45,360	2,700	40,820	2,430	30,240	1,800	24,190	1,570
EPDB2015-18-SD	0.75	1.5	18	0.09	40,320	2,270	36,290	2,040	26,880	1,510	21,500	1,220
EPDB2020-8-SD	1	2	8	0.4	37,800	3,410	34,020	3,060	25,200	2,270	20,160	1,910
EPDB2020-16-SD	1	2	16	0.24	34,020	2,450	30,620	2,200	22,680	1,630	18,100	1,570
EPDB2020-24-SD	1	2	24	0.12	30,240	2,060	27,220	1,850	20,160	1,370	16,130	1,220
EPDB2030-12-SD	1.5	3	12	0.6	28,800	4,320	25,920	3,890	19,200	2,880	15,360	1,820
EPDB2030-24-SD	1.5	3	24	0.36	25,920	3,500	23,330	3,150	17,280	2,330	13,820	1,490
EPDB2030-36-SD	1.5	3	36	0.18	23,040	2,940	20,740	2,650	15,360	1,960	12,300	1,320
EPDB2040-16-SD	2	4	16	0.8	20,700	4,140	18,630	3,730	13,800	2,760	11,500	2,300
EPDB2040-32-SD	2	4	32	0.48	18,630	3,360	16,770	3,020	12,420	2,240	10,350	1,860
EPDB2040-48-SD	2	4	48	0.24	16,560	2,820	14,900	2,540	11,040	1,880	9,100	1,640
EPDB2050-20-SD	2.5	5	20	1	16,200	3,890	14,580	3,500	10,800	2,590	8,640	1,560
EPDB2050-40-SD	2.5	5	40	0.6	14,580	3,150	13,120	2,840	9,720	2,100	7,780	1,400

- 【備考】**
- 樹脂の材質によってはエアブローを推奨致します。
 - この標準切削条件表は切削条件の目安を示したものです。実際の加工形状・使用機械・加工目的により条件を調整してください。
 - 機械の回転数が足りない場合は、回転数と送り速度を同じ比率で下げてください。

- 【Note】**
- An air blower is recommended for some resin materials.
 - The cutting conditions shown in the table above are reference cutting conditions, and should be adjusted according to the actual shape to be machined, the machine used, and purpose for machining.
 - If the machine rotation speed is insufficient, reduce the rotation speed and feed rate by the same ratio.

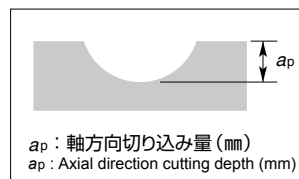

<仕上げ切削> Finishing

被削材 Work material	1		2	
	回転数 n min ⁻¹	送り速度 v_f mm/min	回転数 n min ⁻¹	送り速度 v_f mm/min
ボール半径RE×外径DC Ball radius×Tool dia. (mm)				
アルミニウム合金展伸材 A5052,A7075等, etc. Expanded aluminum alloy material			樹脂 アクリル等 Resin, Acrylic, etc.	
R0.1×0.2	50,000	1,000	50,000	1,000
R0.15×0.3	50,000	1,200	50,000	1,200
R0.2×0.4	50,000	1,500	50,000	1,500
R0.25×0.5	50,000	2,000	50,000	2,000
R0.3×0.6	48,000	1,920	48,000	1,920
R0.4×0.8	44,000	2,200	44,000	2,200
R0.5×1	40,000	2,400	40,000	2,400
R0.75×1.5	34,000	2,400	34,000	2,400
R1×2	30,000	2,400	30,000	2,400
R1.5×3	26,000	2,080	26,000	2,080
R2×4	24,000	1,920	24,000	1,920
R2.5×5	22,000	1,760	22,000	1,760

切り込み量 Depth of Cut (mm)

ap ≤ 0.02mm ~ 0.05mm
ae ≤ 0.02mm ~ 0.05mm

【備考】

- 樹脂の材質によってはエアブローを推奨致します。
- この標準切削条件表は切削条件の目安を示したものです。実際の加工形状・使用機械・加工目的により条件を調整してください。

【Note】

- An air blower is recommended for some resin materials.
- The cutting conditions shown in the table above are reference cutting conditions, and should be adjusted according to the actual shape to be machined, the machine used, and purpose for machining.

エポック SD(S-DLC) スクエア

Epoch SD(S-DLC) Square

ねじれ角: 30°
Helix angle

2枚刃
2flutes



外径公差: 右表参照
Tolerance on dia.: Right table

シャンク径公差: h5
Tolerance on shank

(mm)	
外径 DC Tool dia.	外径公差 Tolerance on dia.
DC ≤ φ6	$\begin{matrix} 0 \\ -0.015 \end{matrix}$
φ7 ≤ DC	$\begin{matrix} 0 \\ -0.020 \end{matrix}$

EPAS2○○○-SD

商品コード Item code	在庫 Stock	寸法 Size (mm)				希望小売価格 (円) Suggested retail price (¥)
		外径 Tool dia.	刃長 Flute length	全長 Overall length	シャンク径 Shank dia.	
EPAS2030-SD	●	3	8	60	6	10,940
EPAS2040-SD	●	4	11	60	6	11,470
EPAS2050-SD	●	5	13	60	6	12,800
EPAS2060-SD	●	6	13	70	6	14,030
EPAS2070-SD	●	7	20	70	8	18,410

商品コード Item code	在庫 Stock	寸法 Size (mm)				希望小売価格 (円) Suggested retail price (¥)
		外径 Tool dia.	刃長 Flute length	全長 Overall length	シャンク径 Shank dia.	
EPAS2080-SD	●	8	20	75	8	17,180
EPAS2090-SD	●	9	20	80	10	23,570
EPAS2100-SD	●	10	25	80	10	23,130
EPAS2110-SD	●	11	25	100	12	31,200
EPAS2120-SD	●	12	25	100	12	28,960

標準切削条件表 Recommended Cutting Conditions EPAS-SD

<側面切削> Side Milling

被削材 Work material	1		2		3		4	
	アルミニウム合金展伸材 A5052,A7075等, etc. Expanded aluminum alloy material		アルミニウム合金鋳物 AC4A,ADC12等, etc. Cast aluminum alloy material		銅合金 C1100等, etc. Pure copper		樹脂 アクリル等 Resin, Acrylic, etc.	
外径 DC Tool dia. (mm)	回転数 n min ⁻¹	送り速度 V_f mm/min	回転数 n min ⁻¹	送り速度 V_f mm/min	回転数 n min ⁻¹	送り速度 V_f mm/min	回転数 n min ⁻¹	送り速度 V_f mm/min
4	24,000	1,800	19,000	1,300	12,000	900	12,000	1,020
6	16,000	2,000	13,000	1,400	8,000	1,000	8,000	1,120
8	12,000	2,000	9,500	1,500	6,000	1,000	6,000	1,120
10	9,500	2,000	7,600	1,500	4,700	1,000	4,700	1,120
12	8,000	2,000	6,400	1,500	4,000	1,000	4,000	1,120

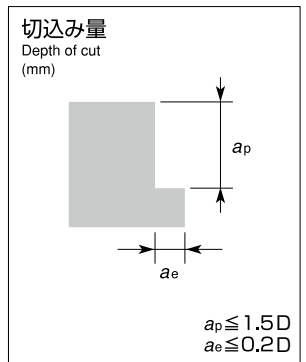

- 【備考】
- 樹脂の材質によってはエアプローチを推奨致します。
 - この標準切削条件表は切削条件の目安を示したものです。実際の加工形状・使用機械・加工目的により条件を調整して下さい。
 - 機械の回転数が足りない場合は、回転数と送り速度を同じ比率で下げてください。

- 【Note】
- An air blower is recommended for some resin materials.
 - The cutting conditions shown in the table above are reference cutting conditions, and should be adjusted according to the actual shape to be machined, the machine used, and purpose for machining.
 - If the machine rotation speed is insufficient, reduce the rotation speed and feed rate by the same ratio.

<溝切削> Slotting

被削材 Work material	1		2		3		4	
	アルミニウム合金展伸材 A5052,A7075等, etc. Expanded aluminum alloy material		アルミニウム合金鋳物 AC4A,ADC12等, etc. Cast aluminum alloy material		銅合金 C1100等, etc. Pure copper		樹脂 アクリル等 Resin, Acrylic, etc.	
外径 DC Tool dia. (mm)	回転数 n min ⁻¹	送り速度 V_f mm/min	回転数 n min ⁻¹	送り速度 V_f mm/min	回転数 n min ⁻¹	送り速度 V_f mm/min	回転数 n min ⁻¹	送り速度 V_f mm/min
4	19,000	1,100	16,000	750	8,750	550	8,750	650
6	13,000	1,200	11,000	850	5,800	530	5,800	580
8	9,500	1,300	8,000	900	4,300	600	4,300	620
10	7,600	1,300	6,400	900	3,500	600	3,500	620
12	6,400	1,300	5,300	900	3,000	610	3,000	660

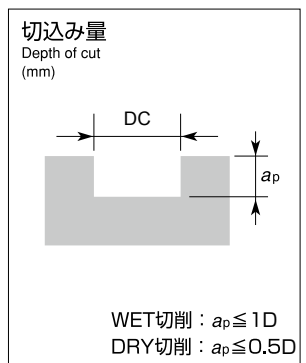

- 【備考】
- 樹脂の材質によってはエアプローチを推奨致します。
 - この標準切削条件表は切削条件の目安を示したものです。実際の加工形状・使用機械・加工目的により条件を調整して下さい。
 - 機械の回転数が足りない場合は、回転数と送り速度を同じ比率で下げてください。

- 【Note】
- An air blower is recommended for some resin materials.
 - The cutting conditions shown in the table above are reference cutting conditions, and should be adjusted according to the actual shape to be machined, the machine used, and purpose for machining.
 - If the machine rotation speed is insufficient, reduce the rotation speed and feed rate by the same ratio.

●印: 標準在庫品です。 ●: Stocked items.

ラインナップ・標準切削条件表

Line Up, Recommended Cutting Conditions

エポック SD(S-DLC) ボール

Epoch SD(S-DLC) Ball

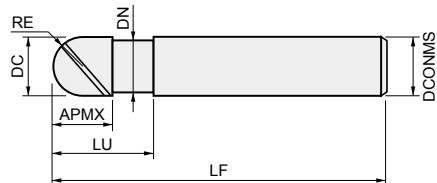

EPAB2000-SD

商品コード Item code	在庫 Stock	寸法 Size (mm)							希望小売価格 (円) Suggested retail price (¥)
		ボール半径 Ball radius RE	外径 Tool dia. DC	首下長 Under neck length LU	刃長 Flute length APMX	首径 Neck dia. DN	全長 Overall length LF	シャック径 Shank dia. DCONMS	
EPAB2060-SD	●	3	6	15	6	5.9	90	6	19,760
EPAB2080-SD	●	4	8	20	8	7.9	100	8	25,810
EPAB2100-SD	●	5	10	25	10	9.9	100	10	32,990
EPAB2120-SD	●	6	12	30	12	11.9	110	12	42,870

標準切削条件表 Recommended Cutting Conditions EPAB-SD

被削材 Work material	1		2		3		4	
	アルミニウム合金展伸材 A5052, A7075等, etc. Expanded aluminum alloy material		アルミニウム合金鋳物 AC4A, ADC12等, etc. Cast aluminum alloy material		銅合金 C1100等, etc. Pure copper		樹脂 アクリル等 Resin, Acrylic, etc.	
ボール半径RE×外径DC Ball radius×Tool dia. (mm)	回転数 n min ⁻¹	送り速度 v_f mm/min	回転数 n min ⁻¹	送り速度 v_f mm/min	回転数 n min ⁻¹	送り速度 v_f mm/min	回転数 n min ⁻¹	送り速度 v_f mm/min
R3×6	27,000	3,300	21,600	2,310	13,300	1,600	10,600	1,280
R4×8	20,000	3,200	16,000	2,240	10,000	1,400	8,000	1,120
R5×10	16,000	3,000	12,800	2,100	8,000	1,280	6,400	1,030
R6×12	13,300	2,660	10,640	1,860	6,600	1,190	5,300	950

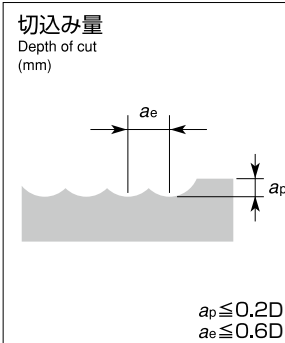

【備考】 ①樹脂の材質によってはエアブローを推奨致します。
②この標準切削条件表は切削条件の目安を示したものです。
実際の加工形状・使用機械・加工目的により条件を調整して下さい。
③機械の回転数が足りない場合は、回転数と送り速度を同じ比率で下げてください。

【Note】 ① An air blower is recommended for some resin materials.
② The cutting conditions shown in the table above are reference cutting conditions, and should be adjusted according to the actual shape to be machined, the machine used, and purpose for machining.
③ If the machine rotation speed is insufficient, reduce the rotation speed and feed rate by the same ratio.

<仕上げ切削> Finishing

被削材 Work material	1		2	
	アルミニウム合金展伸材 A5052, A7075等, etc. Expanded aluminum alloy material		樹脂 アクリル等 Resin, Acrylic, etc.	
ボール半径RE×外径DC Ball radius×Tool dia. (mm)	回転数 n min ⁻¹	送り速度 v_f mm/min	回転数 n min ⁻¹	送り速度 v_f mm/min
R3×6	20,000	1,600	20,000	1,600
R4×8	15,000	1,200	15,000	1,200
R5×10	12,000	1,200	12,000	1,200
R6×12	10,000	1,000	10,000	1,000

切り込み量 Depth of Cut (mm)

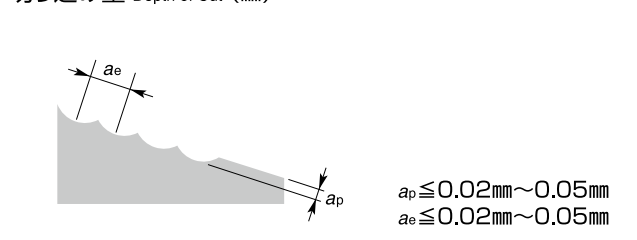

【備考】 ①樹脂の材質によってはエアブローを推奨致します。
②この標準切削条件表は切削条件の目安を示したものです。
実際の加工形状・使用機械・加工目的により条件を調整して下さい。

【Note】 ① An air blower is recommended for some resin materials.
② The cutting conditions shown in the table above are reference cutting conditions, and should be adjusted according to the actual shape to be machined, the machine used, and purpose for machining.

●印：標準在庫品です。 ●：Stocked items.

SD(S-DLC) 超硬OHノンステップボーラー

アルミ用

SD(S-DLC) Coating Carbide Oil Hole Non Step Borer for Aluminium

SD (S-DLC) コーティングでアルミの穴加工を変える!

SD (S-DLC) Coating will change aluminum drilling!

高能率加工はノンステップで!!

High-efficiency machining with Non-Step Borer!!

特殊溝形状と溝面にて切りくず排出性を向上。SD (S-DLC) コーティングにて切りくずを細かく分断し、安定した切りくず処理にて高速加工を実現。

Improved chip removal using special groove shape and groove surface. Chips are cut finely due to SD (S-DLC) Coating, enabling high-speed machining with stable chip handling.

$v_c=170\text{m/min}$
 $v_f=3,600\text{mm/min}$

高送りでも安定した切りくず形状。
Well-shape chips by high-feed boring.



高送り加工が可能!!

High-feed-rate machining is possible!!

先端特殊形状とSD (S-DLC) コーティングにより切削抵抗が大幅に減少。送り速度が大幅にUPし飛躍的に能率が上がります。

Special tip shape and SD (S-DLC) Coating greatly reduces cutting resistance, so feed rate can be greatly increased, providing a leap in cutting efficiency.

先端特殊形状

Special tip shape



スラスト比較 Comparison of thrust

工具径×穴深さ Tool dia. × Hole depth = $\phi 6.0 \times 33\text{mm}$ (5D)

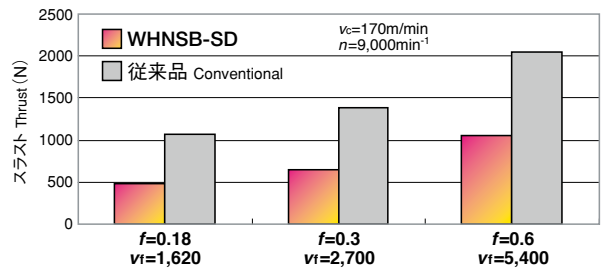

横型M/C、水溶性内部給油 (2.0MPa)、ワーク: AC4B
Horizontal M/C, Water base internal coolant (2.0MPa), Work: AC4B

高い耐溶着性に優れたSD (S-DLC) コーティング!!

High welding resistance with superior SD (S-DLC) coating!!

密着性の良いSD (S-DLC) コーティングにてすくい面の溶着が大幅に減少。中心部の溶着も、先端特殊形状とSD (S-DLC) コーティングで減少します。

SD (S-DLC) Coating with good welding resistance greatly reduces welding of face surface. Welding of the center area is also reduced by the use of special tip shape and SD (S-DLC) Coating.

【200穴加工時の状態比較】 $v_c=170\text{m/min}$ 、 $v_f=3,000\text{mm/min}$ 。水溶性内部給油 (2.0MPa)、被削材: AC2A
Comparison of condition after drilling 200 holes internal supply of water-based cutting agent (2.0MPa); Work material: AC2A

05WHNSB0600-SD

ノンコーティングオイルホールドリル Non Coating Oil Hole Drill



ラインナップ

Line Up

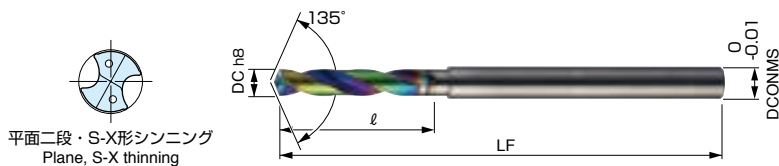

03WHNSB○○○○-SD

L/D=3

商品コード Item code	在庫 Stock	寸法 Size (mm)				希望小売価格 (円) Suggested retail price (¥)
		直径 Tool dia. DC	溝長 Flute length ℓ	全長 Overall length LF	シャンク径 Shank dia. DCONMS	
03WHNSB0300-SD	●	3.0	19	69	3.0	15,380
03WHNSB0303-SD	●	3.03	23	73	4.0	15,710
03WHNSB0310-SD	□	3.1	23	73	4.0	—
03WHNSB0320-SD	□	3.2	23	73	4.0	—
03WHNSB0330-SD	□	3.3	23	73	4.0	—
03WHNSB0340-SD	□	3.4	23	73	4.0	—
03WHNSB0350-SD	□	3.5	23	73	4.0	—
03WHNSB0353-SD	□	3.53	23	73	4.0	—
03WHNSB0360-SD	□	3.6	23	73	4.0	—
03WHNSB0370-SD	□	3.7	23	73	4.0	—
03WHNSB0380-SD	□	3.8	23	73	4.0	—
03WHNSB0390-SD	□	3.9	23	73	4.0	—
03WHNSB0400-SD	●	4.0	23	73	4.0	16,050
03WHNSB0403-SD	●	4.03	29	82	5.0	16,390
03WHNSB0410-SD	□	4.1	29	82	5.0	—
03WHNSB0420-SD	□	4.2	29	82	5.0	—
03WHNSB0430-SD	□	4.3	29	82	5.0	—
03WHNSB0440-SD	□	4.4	29	82	5.0	—
03WHNSB0450-SD	□	4.5	29	82	5.0	—
03WHNSB0453-SD	□	4.53	29	82	5.0	—
03WHNSB0460-SD	□	4.6	29	82	5.0	—
03WHNSB0470-SD	□	4.7	29	82	5.0	—
03WHNSB0480-SD	□	4.8	29	82	5.0	—
03WHNSB0490-SD	□	4.9	29	82	5.0	—
03WHNSB0500-SD	●	5.0	29	82	5.0	16,610
03WHNSB0503-SD	●	5.03	29	82	6.0	17,520
03WHNSB0510-SD	●	5.1	29	82	6.0	17,520
03WHNSB0520-SD	□	5.2	29	82	6.0	—
03WHNSB0530-SD	□	5.3	29	82	6.0	—
03WHNSB0540-SD	□	5.4	29	82	6.0	—
03WHNSB0550-SD	●	5.5	29	82	6.0	17,520
03WHNSB0553-SD	●	5.53	29	82	6.0	17,960
03WHNSB0560-SD	□	5.6	29	82	6.0	—
03WHNSB0570-SD	□	5.7	29	82	6.0	—
03WHNSB0580-SD	□	5.8	29	82	6.0	—
03WHNSB0590-SD	□	5.9	29	82	6.0	—
03WHNSB0600-SD	●	6.0	29	82	6.0	17,960
03WHNSB0603-SD	●	6.03	34	89	7.0	19,080
03WHNSB0610-SD	□	6.1	34	89	7.0	—
03WHNSB0620-SD	□	6.2	34	89	7.0	—
03WHNSB0630-SD	□	6.3	34	89	7.0	—
03WHNSB0640-SD	□	6.4	34	89	7.0	—
03WHNSB0650-SD	●	6.5	34	89	7.0	19,080

商品コード Item code	在庫 Stock	寸法 Size (mm)				希望小売価格 (円) Suggested retail price (¥)
		直径 Tool dia. DC	溝長 Flute length ℓ	全長 Overall length LF	シャンク径 Shank dia. DCONMS	
03WHNSB0653-SD	●	6.53	34	89	7.0	19,530
03WHNSB0660-SD	□	6.6	34	89	7.0	—
03WHNSB0670-SD	□	6.7	34	89	7.0	—
03WHNSB0680-SD	●	6.8	34	89	7.0	19,530
03WHNSB0690-SD	□	6.9	34	89	7.0	—
03WHNSB0700-SD	●	7	34	89	7.0	19,530
03WHNSB0703-SD	●	7.03	39	95	8.0	21,320
03WHNSB0710-SD	□	7.1	39	95	8.0	—
03WHNSB0720-SD	□	7.2	39	95	8.0	—
03WHNSB0730-SD	●	7.3	39	95	8.0	21,320
03WHNSB0740-SD	□	7.4	39	95	8.0	—
03WHNSB0750-SD	●	7.5	39	95	8.0	21,320
03WHNSB0753-SD	●	7.53	39	95	8.0	21,660
03WHNSB0760-SD	□	7.6	39	95	8.0	—
03WHNSB0770-SD	□	7.7	39	95	8.0	—
03WHNSB0780-SD	□	7.8	39	95	8.0	—
03WHNSB0790-SD	□	7.9	39	95	8.0	—
03WHNSB0800-SD	●	8.0	39	95	8.0	21,660
03WHNSB0803-SD	●	8.03	44	101	9.0	23,130
03WHNSB0810-SD	□	8.1	44	101	9.0	—
03WHNSB0820-SD	□	8.2	44	101	9.0	—
03WHNSB0830-SD	□	8.3	44	101	9.0	—
03WHNSB0840-SD	□	8.4	44	101	9.0	—
03WHNSB0850-SD	●	8.5	44	101	9.0	23,130
03WHNSB0853-SD	●	8.53	44	101	9.0	23,570
03WHNSB0860-SD	●	8.6	44	101	9.0	23,570
03WHNSB0870-SD	□	8.7	44	101	9.0	—
03WHNSB0880-SD	●	8.8	44	101	9.0	23,570
03WHNSB0890-SD	□	8.9	44	101	9.0	—
03WHNSB0900-SD	●	9.0	44	101	9.0	23,570
03WHNSB0903-SD	●	9.03	49	107	10.0	25,140
03WHNSB0910-SD	□	9.1	49	107	10.0	—
03WHNSB0920-SD	□	9.2	49	107	10.0	—
03WHNSB0930-SD	□	9.3	49	107	10.0	—
03WHNSB0940-SD	□	9.4	49	107	10.0	—
03WHNSB0950-SD	●	9.5	49	107	10.0	25,140
03WHNSB0953-SD	●	9.53	49	107	10.0	25,700
03WHNSB0960-SD	□	9.6	49	107	10.0	—
03WHNSB0970-SD	□	9.7	49	107	10.0	—
03WHNSB0980-SD	□	9.8	49	107	10.0	—
03WHNSB0990-SD	□	9.9	49	107	10.0	—
03WHNSB1000-SD	●	10.0	49	107	10.0	25,700
03WHNSB1003-SD	●	10.03	54	117	11.0	27,380

●印：標準在庫品です。 □印：特定代理店在庫です。弊社営業へお問合せください。
● : Stocked items. □ : Stocked by specified distributor. Contact with our sales department.

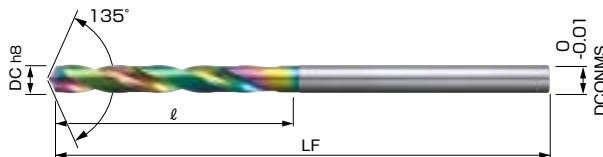
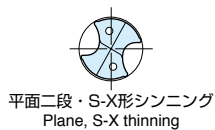

05WHNSB $\circ\circ\circ\circ$ -SD **L/D=5**

商品コード Item code	在庫 Stock	寸法 Size (mm)				希望小売価格 (円) Suggested retail price (¥)
		直径 Tool dia. DC	溝長 Flute length ℓ	全長 Overall length LF	シャンク径 Shank dia. DCONMS	
05WHNSB0200-SD	●	2.0	20	66	3.0	17,520
05WHNSB0203-SD	●	2.03	24	74	3.0	17,520
05WHNSB0210-SD	●	2.1	24	74	3.0	17,520
05WHNSB0220-SD	●	2.2	24	74	3.0	17,520
05WHNSB0230-SD	●	2.3	24	74	3.0	17,520
05WHNSB0240-SD	●	2.4	24	74	3.0	17,520
05WHNSB0250-SD	●	2.5	24	74	3.0	17,520
05WHNSB0253-SD	●	2.53	29	79	3.0	17,520
05WHNSB0260-SD	●	2.6	29	79	3.0	17,520
05WHNSB0270-SD	●	2.7	29	79	3.0	17,520
05WHNSB0280-SD	●	2.8	29	79	3.0	17,520
05WHNSB0290-SD	●	2.9	29	79	3.0	17,520
05WHNSB0300-SD	●	3.0	29	79	3.0	17,520
05WHNSB0303-SD	●	3.03	37	87	4.0	18,080
05WHNSB0310-SD	□	3.1	37	87	4.0	—
05WHNSB0320-SD	□	3.2	37	87	4.0	—
05WHNSB0330-SD	□	3.3	37	87	4.0	—
05WHNSB0340-SD	□	3.4	37	87	4.0	—
05WHNSB0350-SD	●	3.5	37	87	4.0	18,080
05WHNSB0353-SD	●	3.53	37	87	4.0	18,190
05WHNSB0360-SD	□	3.6	37	87	4.0	—
05WHNSB0370-SD	□	3.7	37	87	4.0	—
05WHNSB0380-SD	□	3.8	37	87	4.0	—
05WHNSB0390-SD	□	3.9	37	87	4.0	—
05WHNSB0400-SD	●	4.0	37	87	4.0	18,190
05WHNSB0403-SD	●	4.03	47	100	5.0	18,750
05WHNSB0410-SD	●	4.1	47	100	5.0	18,750
05WHNSB0420-SD	●	4.2	47	100	5.0	18,750
05WHNSB0430-SD	●	4.3	47	100	5.0	18,750
05WHNSB0440-SD	□	4.4	47	100	5.0	—
05WHNSB0450-SD	●	4.5	47	100	5.0	18,750
05WHNSB0453-SD	●	4.53	47	100	5.0	19,080
05WHNSB0460-SD	□	4.6	47	100	5.0	—
05WHNSB0470-SD	□	4.7	47	100	5.0	—
05WHNSB0480-SD	□	4.8	47	100	5.0	—
05WHNSB0490-SD	□	4.9	47	100	5.0	—
05WHNSB0500-SD	●	5.0	47	100	5.0	19,080
05WHNSB0503-SD	●	5.03	47	100	6.0	20,200
05WHNSB0510-SD	●	5.1	47	100	6.0	20,200
05WHNSB0520-SD	□	5.2	47	100	6.0	—
05WHNSB0530-SD	□	5.3	47	100	6.0	—
05WHNSB0540-SD	□	5.4	47	100	6.0	—
05WHNSB0550-SD	●	5.5	47	100	6.0	20,200
05WHNSB0553-SD	●	5.53	47	100	6.0	20,430
05WHNSB0560-SD	□	5.6	47	100	6.0	—
05WHNSB0570-SD	□	5.7	47	100	6.0	—
05WHNSB0580-SD	□	5.8	47	100	6.0	—
05WHNSB0590-SD	□	5.9	47	100	6.0	—
05WHNSB0600-SD	●	6.0	47	100	6.0	20,430

商品コード Item code	在庫 Stock	寸法 Size (mm)				希望小売価格 (円) Suggested retail price (¥)
		直径 Tool dia. DC	溝長 Flute length ℓ	全長 Overall length LF	シャンク径 Shank dia. DCONMS	
05WHNSB0603-SD	●	6.03	55	110	7.0	21,770
05WHNSB0610-SD	□	6.1	55	110	7.0	—
05WHNSB0620-SD	□	6.2	55	110	7.0	—
05WHNSB0630-SD	□	6.3	55	110	7.0	—
05WHNSB0640-SD	□	6.4	55	110	7.0	—
05WHNSB0650-SD	●	6.5	55	110	7.0	21,770
05WHNSB0653-SD	●	6.53	55	110	7.0	22,330
05WHNSB0660-SD	□	6.6	55	110	7.0	—
05WHNSB0670-SD	□	6.7	55	110	7.0	—
05WHNSB0680-SD	●	6.8	55	110	7.0	22,330
05WHNSB0690-SD	□	6.9	55	110	7.0	—
05WHNSB0700-SD	●	7.0	55	110	7.0	22,330
05WHNSB0703-SD	●	7.03	63	119	8.0	24,130
05WHNSB0710-SD	□	7.1	63	119	8.0	—
05WHNSB0720-SD	□	7.2	63	119	8.0	—
05WHNSB0730-SD	□	7.3	63	119	8.0	—
05WHNSB0740-SD	□	7.4	63	119	8.0	—
05WHNSB0750-SD	●	7.5	63	119	8.0	24,130
05WHNSB0753-SD	●	7.53	63	119	8.0	24,810
05WHNSB0760-SD	□	7.6	63	119	8.0	—
05WHNSB0770-SD	□	7.7	63	119	8.0	—
05WHNSB0780-SD	●	7.8	63	119	8.0	24,810
05WHNSB0790-SD	□	7.9	63	119	8.0	—
05WHNSB0800-SD	●	8.0	63	119	8.0	24,810
05WHNSB0803-SD	●	8.03	71	128	9.0	26,370
05WHNSB0810-SD	□	8.1	71	128	9.0	—
05WHNSB0820-SD	□	8.2	71	128	9.0	—
05WHNSB0830-SD	□	8.3	71	128	9.0	—
05WHNSB0840-SD	□	8.4	71	128	9.0	—
05WHNSB0850-SD	●	8.5	71	128	9.0	26,370
05WHNSB0853-SD	●	8.53	71	128	9.0	27,050
05WHNSB0860-SD	●	8.6	71	128	9.0	27,050
05WHNSB0870-SD	□	8.7	71	128	9.0	—
05WHNSB0880-SD	●	8.8	71	128	9.0	27,050
05WHNSB0890-SD	□	8.9	71	128	9.0	—
05WHNSB0900-SD	●	9.0	71	128	9.0	27,050
05WHNSB0903-SD	●	9.03	79	137	10.0	28,850
05WHNSB0910-SD	□	9.1	79	137	10.0	—
05WHNSB0920-SD	□	9.2	79	137	10.0	—
05WHNSB0930-SD	□	9.3	79	137	10.0	—
05WHNSB0940-SD	□	9.4	79	137	10.0	—
05WHNSB0950-SD	●	9.5	79	137	10.0	28,850
05WHNSB0953-SD	●	9.53	79	137	10.0	29,180
05WHNSB0960-SD	□	9.6	79	137	10.0	—
05WHNSB0970-SD	□	9.7	79	137	10.0	—
05WHNSB0980-SD	●	9.8	79	137	10.0	29,180
05WHNSB0990-SD	□	9.9	79	137	10.0	—
05WHNSB1000-SD	●	10.0	79	137	10.0	29,180
05WHNSB1003-SD	●	10.03	87	150	11.0	31,200

ラインナップ

Line Up

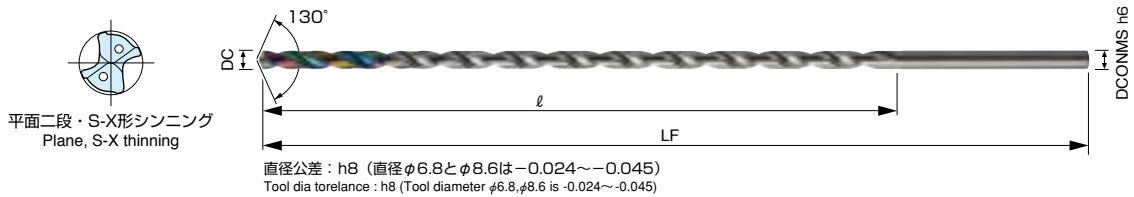

15WHNSB-SD L/D=15

商品コード Item code	在庫 Stock	寸法 Size (mm)				希望小売価格 (円) Suggested retail price (¥)
		直径 Tool dia.	溝長 Flute length	全長 Overall length	シャンク径 Shank dia.	
		DC	ℓ	LF	DCONMS	
15WHNSB0300-SD	●	3.0	54	102	3.0	30,860
15WHNSB0350-SD	□	3.5	63	111	4.0	—
15WHNSB0400-SD	●	4.0	72	121	4.0	31,650
15WHNSB0450-SD	□	4.5	81	132	5.0	—
15WHNSB0500-SD	●	5.0	91	142	5.0	33,100
15WHNSB0550-SD	●	5.5	100	151	6.0	35,240
15WHNSB0600-SD	●	6.0	109	160	6.0	37,480
15WHNSB0650-SD	□	6.5	118	171	7.0	—
15WHNSB0680-SD	□	6.8	127	180	7.0	—
15WHNSB0700-SD	●	7.0	127	180	7.0	42,980
15WHNSB0750-SD	□	7.5	136	191	8.0	—
15WHNSB0800-SD	●	8.0	145	200	8.0	47,360
15WHNSB0850-SD	□	8.5	154	209	9.0	—
15WHNSB0860-SD	□	8.6	163	218	9.0	—
15WHNSB0900-SD	●	9.0	163	218	9.0	52,630
15WHNSB0950-SD	□	9.5	172	227	10.0	—
15WHNSB1000-SD	●	10.0	181	236	10.0	57,230

20WHNSB-SD L/D=20

商品コード Item code	在庫 Stock	寸法 Size (mm)				希望小売価格 (円) Suggested retail price (¥)
		直径 Tool dia.	溝長 Flute length	全長 Overall length	シャンク径 Shank dia.	
		DC	ℓ	LF	DCONMS	
20WHNSB0300-SD	●	3.0	69	117	3.0	35,580
20WHNSB0350-SD	□	3.5	81	129	4.0	—
20WHNSB0400-SD	●	4.0	92	141	4.0	36,470
20WHNSB0450-SD	□	4.5	104	155	5.0	—
20WHNSB0500-SD	●	5.0	116	167	5.0	38,150
20WHNSB0550-SD	●	5.5	127	178	6.0	40,630
20WHNSB0600-SD	●	6.0	139	190	6.0	43,090
20WHNSB0650-SD	□	6.5	150	203	7.0	—
20WHNSB0680-SD	□	6.8	162	215	7.0	—
20WHNSB0700-SD	●	7.0	162	215	7.0	49,150
20WHNSB0750-SD	□	7.5	173	228	8.0	—
20WHNSB0800-SD	●	8.0	185	240	8.0	54,650

25WHNSB-SD L/D=25

商品コード Item code	在庫 Stock	寸法 Size (mm)				希望小売価格 (円) Suggested retail price (¥)
		直径 Tool dia.	溝長 Flute length	全長 Overall length	シャンク径 Shank dia.	
		DC	ℓ	LF	DCONMS	
25WHNSB0300-SD	●	3.0	84	132	3.0	37,260
25WHNSB0350-SD	□	3.5	98	146	4.0	—
25WHNSB0400-SD	●	4.0	113	162	4.0	40,180
25WHNSB0450-SD	□	4.5	127	178	5.0	—
25WHNSB0500-SD	●	5.0	141	192	5.0	41,860
25WHNSB0550-SD	●	5.5	155	206	6.0	44,660
25WHNSB0600-SD	●	6.0	169	220	6.0	47,360
25WHNSB0650-SD	□	6.5	183	236	7.0	—
25WHNSB0680-SD	□	6.8	191	244	7.0	—
25WHNSB0700-SD	●	7.0	197	250	7.0	54,090
25WHNSB0750-SD	□	7.5	211	266	8.0	—
25WHNSB0800-SD	●	8.0	225	280	8.0	60,150

30WHNSB-SD L/D=30

商品コード Item code	在庫 Stock	寸法 Size (mm)				希望小売価格 (円) Suggested retail price (¥)
		直径 Tool dia.	溝長 Flute length	全長 Overall length	シャンク径 Shank dia.	
		DC	ℓ	LF	DCONMS	
30WHNSB0300-SD	●	3.0	99	147	3.0	38,940
30WHNSB0350-SD	□	3.5	116	164	4.0	—
30WHNSB0400-SD	●	4.0	132	181	4.0	48,370
30WHNSB0450-SD	□	4.5	149	200	5.0	—
30WHNSB0500-SD	●	5.0	166	217	5.0	58,690
30WHNSB0550-SD	●	5.5	182	233	6.0	65,420
30WHNSB0600-SD	●	6.0	199	250	6.0	68,570

●印:標準在庫品です。 □印:特定代理店在庫です。弊社営業へお問合せください。
 ●: Stocked Items. □: Stocked by specified distributor. Contact with our sales department.

標準切削条件表

Recommended Cutting Conditions

水溶性内部クーラント切削条件 Cutting Conditions (Water base internal coolant)

被削材 Work material	アルミ合金 Aluminum alloy material Mg系 (5052)		アルミ合金 Aluminum alloy material Zn-Mg系 (7075)		アルミ合金鋳物 Cast aluminum alloy material AC系、ADC		銅合金 Copper alloys	
	直径 Tool dia.	切削速度 v_c (m/min)	送り量 f (mm/rev)	切削速度 v_c (m/min)	送り量 f (mm/rev)	切削速度 v_c (m/min)	送り量 f (mm/rev)	切削速度 v_c (m/min)
Φ2.0	80~180	0.04~0.08	60~150	0.06~0.10	80~160	0.06~0.10	60~150	0.04~0.08
Φ4.0	80~200	0.08~0.16	60~150	0.12~0.20	80~160	0.12~0.20	60~150	0.08~0.16
Φ6.0	80~200	0.12~0.24	80~180	0.18~0.30	80~180	0.18~0.30	80~180	0.12~0.24
Φ8.0	80~200	0.16~0.30	80~180	0.24~0.40	80~180	0.24~0.40	80~180	0.16~0.30
Φ10.0	80~200	0.18~0.35	80~180	0.25~0.50	80~200	0.25~0.50	80~180	0.18~0.35

切削条件の選定について Setting of Cutting Conditions

- *被削材、加工形状に合わせて、適切なクーラントを使用してください。
- *この標準切削条件表は切削条件の目安を示すものです。実際の加工では加工形状、目的、使用機械等により条件を調整してください。
- *この内部クーラント切削条件基準は水溶性切削油剤を使用する場合のものです。又Φ5.0以下はクーラント圧2.0MPa以上必要です。
- *MQL (ミスト) 加工の場合はミスト装置や工具からの吐出量により切削速度を下げないと加工できない場合があります。
- *MQL (ミスト) 加工にてA7075を加工する場合はご相談願います。
- *工具装着の際は傷や汚れのないコレットを用い、工具の振れは0.02mm以下に抑えてください。

- Use the appropriate coolant for the work material and machining shape.
- These Recommended Cutting Conditions indicate only the rule of a thumb for the cutting conditions. In actual machining, the condition should be adjusted according to the machining shape, purpose and the machine type.
- Internal coolant cutting condition standards above are when water-soluble cutting lubricant is used. In addition, for $\phi 5.0$ or less, coolant pressure of 2.0MPa or more is required.
- For MQL (mist) machining, depending on the mist equipment and amount discharged by the tool, it may be necessary to reduce cutting speed in order to perform machining.
- For MQL (mist) machining of A7075, please consult us.
- When mounting the tool, use a collet without scratches or stains and suppress tool run out to 0.02mm or less.

15~30WHNSB-SD 加工方法 How to use 15~30WHNSB-SD

1 下穴 (ガイド穴) 加工 (03~05WHNSB-SD)

Drilling of pilot hole (guide hole) (03~05WHNSB-SD)

- 穴深さ：工具径×2倍~4倍
Hole depth : tool diameter ×2.0~4.0 times



2 低速回転、クーラントON (15~30WHNSB-SD)

Supplying coolant during low-speed revolution (15~30WHNSB-SD)

- 低速回転でガイド穴へ ($n=0\sim 500\text{min}^{-1}$)
Leading to the guide hole at low speed ($n=0\sim 500\text{min}^{-1}$)
- ガイド穴加工終了面より2.0~5.0mm手前で送りをストップ
Stop feed 2.0~5.0 mm before the end of the guide hole.

※工具刃長が200mm以上の場合は、回転数 $n=200\text{min}^{-1}$ 以下でガイド穴へ
When a long tool (200mm or longer) is used, position the tool to the guide hole at low revolution speed ($n=200\text{min}^{-1}$ or less).



3 切削回転、切削送り (15~30WHNSB-SD)

High-speed revolution for drilling feed (15~30WHNSB-SD)

- 回転数が正規に上がるの確認し切削送り開始
After confirming that the revolution speed is increasing at the specified rate, start feeding.

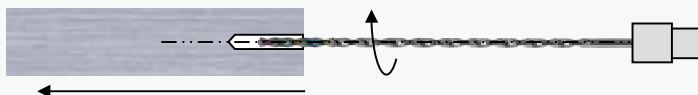

4 加工終了

Machining completion

- 低速回転にて工具を抜く ($n=0\sim 500\text{min}^{-1}$)
Withdraw the tool at low speed. ($n=0\sim 500\text{min}^{-1}$)





図、表等のデータは試験結果の一例であり、保証値ではありません。
「MOLDINO」は株式会社MOLDINOの登録商標です。

The diagrams and table data are examples of test results, and are not guaranteed values.
"MOLDINO" is a registered trademark of MOLDINO Tool Engineering, Ltd.

安全上のご注意 Attention on Safety

1. 取扱上のご注意

- (1) 工具をケース(梱包)から取り出す際は、工具の飛び出し、落下にご注意ください。特に工具刃部との接触には十分ご注意ください。
- (2) 鋭利な切れ刃を有する工具を取扱う際は、切れ刃を素手で直接触れないように注意してください。

2. 取付け時のご注意

- (1) ご使用前に、工具の傷・割れ等の外観確認を行っていただき、コレットチャック等への取付けは確実に行ってください。
- (2) ご使用にあたって、インサートのセッティングは確実に行っていただき、アール等への取付も確実に行ってください。
- (3) ご使用中に、異常な振動等が発生した場合は、直ちに機械を停止させて、その振動の原因を取り除いてください。

3. 使用上のご注意

- (1) 切削工具あるいは被削材の寸法・回転の方向は、あらかじめ確認しておいてください。
- (2) 標準切削条件表の数値は、新しい作業の立上げの目安としてご利用ください。切込みが大きい場合、使用機械の剛性が小さい場合あるいは被加工物の性状に応じて切削条件を適正に調整してご使用ください。
- (3) 切削工具材料は硬質の材料です。ご使用中に破損して飛散する場合があります。また、切りくずが飛散することがあります。これらの飛散物等は作業者を切傷させ、火傷あるいは目に入って負傷させる恐れがありますので、工具をご使用中はその周囲に安全カバーを取付け、保護メガネ等の保護具を着用して安全な環境下での作業をお願いします。
- (4) 切削中に発生する火花や、破損による発熱や、切りくずによる引火・火災の危険があります。引火や爆発の危険のあるところでは使用しないでください。不水溶性切削液をご使用される場合は防火対策を必ず行なってください。
- (5) 工具を本来の目的以外にはご使用にならないでください。

4. 再研削時のご注意

- (1) 再研削時期が不適当であると工具が破損する恐れがあります。適正な工具と交換するか、再研削を行ってください。
- (2) 工具を再研削しますと粉塵が発生します。再研削時にはその周囲に安全カバーを取付け、保護メガネ等の保護具を着用してください。
- (3) 本製品には特定化学物質に指定されたコバルト及びその無機化合物が含まれています。再研削等の加工を加える場合は特定化学物質障害予防規則(特化則)に従った取扱いをしてください。

5. 工具に関して、安全上の問題点・不明の点・その他相談がありましたら

フリーダイヤル技術相談へご相談ください。

1. Cautions regarding handling

- (1) When removing the tool from its case (packaging), be careful that the tool does not pop out or is dropped. Be particularly careful regarding contact with the tool flutes.
- (2) When handling tools with sharp cutting flutes, be careful not to touch the cutting flutes directly with your bare hands.

2. Cautions regarding mounting

- (1) Before use, check the outside appearance of the tool for scratches, cracks, etc. and that it is firmly mounted in the collet chuck, etc.
- (2) When preparing for use, be sure that the inserts are firmly mounted in place and that they are firmly mounted on the arbor, etc.
- (3) If abnormal chattering, etc. occurs during use, stop the machine immediately and remove the cause of the chattering.

3. Cautions during use

- (1) Before use, confirm the dimensions and direction of rotation of the tool and milling work material.
- (2) The numerical values in the standard cutting conditions table should be used as criteria when starting new work. The cutting conditions should be adjusted as appropriate when the cutting depth is large, the rigidity of the machine being used is low, or according to the conditions of the work material.
- (3) Cutting tools are made of a hard material. During use, they may break and fly off. In addition, cutting chips may also fly off. Since there is a danger of injury to workers, fire, or eye damage from such flying pieces, a safety cover should be attached when work is performed and safety equipment such as safety goggles should be worn to create a safe environment for work.
- (4) There is a risk of fire or inflammation due to sparks, heat due to breakage, and cutting chips. Do not use where there is a risk of fire or explosion. Please caution of fire while using oil base coolant, fire prevention is necessary.
- (5) Do not use the tool for any purpose other than that for which it is intended.

4. Cautions regarding regrinding

- (1) If regrinding is not performed at the proper time, there is a risk of the tool breaking. Replace the tool with one in good condition, or perform regrinding.
- (2) Grinding dust will be created when regrinding a tool. When regrinding, be sure to attach a safety cover over the work area and wear safety clothes such as safety goggles, etc.
- (3) This product contains the specified chemical substance cobalt and its inorganic compounds. When performing regrinding or similar processing, be sure to handle the processing in accordance with the local laws and regulations regarding prevention of hazards due to specified chemical substances.

株式会社 MOLDINO

MOLDINO Tool Engineering, Ltd.

本社 〒130-0026 東京都墨田区両国4-31-11(ヒューリック両国ビル8階)
☎ 03-6890-5101 FAX 03-6890-5134
International Sales Dept.: ☎ +81-3-6890-5103 FAX +81-3-6890-5128

営業企画部	☎ 03-6890-5102 FAX03-6890-5134	海外営業部	☎ 03-6890-5103 FAX03-6890-5128
東京営業所	☎ 03-6890-5110 FAX03-6890-5133	静岡営業所	☎ 054-273-0360 FAX054-273-0361
東北営業所	☎ 022-208-5100 FAX022-208-5102	名古屋営業所	☎ 052-687-9150 FAX052-687-9144
新潟営業所	☎ 0258-87-1224 FAX0258-87-1158	大阪営業所	☎ 06-7668-0190 FAX06-7668-0194
東関東営業所	☎ 0294-88-9430 FAX0294-88-9432	中四営業所	☎ 082-536-2001 FAX082-536-2003
長野営業所	☎ 0268-21-3700 FAX0268-21-3711	九州営業所	☎ 092-289-7010 FAX092-289-7012
北関東営業所	☎ 0276-59-6001 FAX0276-59-6005		
神奈川営業所	☎ 046-400-9429 FAX046-400-9435		

ヨーロッパ / MOLDINO Tool Engineering Europe GmbH Itterpark 12, 40724 Hilden, Germany. TEL: +49-(0)2103-24820. FAX: +49-(0)2103-248230
 中国 / MOLDINO Tool Engineering (Shanghai) Ltd. Room 2004-2605, Metro Plaza, 555 Loushanguan Road, Changning District, Shanghai, 200051, CHINA TEL: +86-(0)21-3368-3058. FAX: +86-(0)21-3368-3050
 アメリカ / MITSUBISHI MATERIALS U.S.A. CORPORATION 41700 Gardenbrook Road, Suite 120, Novi, MI 48375-1320 U.S.A. TEL: +1(248)308-2620. FAX: +1(248)308-2627
 メキシコ / MMC METAL DE MEXICO, S.A. DE C.V. Av. La Cañada No.16, Parque Industrial Bernardo Quintana, El Marques, Querétaro, CP 76246, México TEL: +52-442-1926800
 ブラジル / MMC METAL DO BRASIL, LDA. Rua Cincinnati Braga, 340 13º andar, Bela Vista - CEP 01333-010 São Paulo - SP., Brasil TEL: +55(11)3506-5600 FAX: +55(11)3506-5677
 タイ / MMC Hardmetal (Thailand) Co., Ltd. MOLDINO Division 622 Emportum Tower, Floor 22/14, Sukhumvit Road, Klong Toei, Bangkok 10110, Thailand TEL: +66-(0)2-661-8175 FAX: +66-(0)2-661-8176
 インド / MMC Hardmetal India Pvt Ltd. H.O.: Prasad Enclave, #118/119, 1st Floor, 2nd Stage, 5th main, BBMP Ward #11, (New #38), Industrial Suburb, Yeshwanthpura, Bengaluru, 560 022, Karnataka, India. Tel: +91-80-2204-3600

ホームページ <http://www.moldino.com> フリーダイヤル技術相談 ☎0120-134159

工具選定データベース [TOOL SEARCH]

TOOLSEARCH 検索

店名